

Tumble Dryers

25 Pound Capacity

30 Pound Capacity

35 Pound Capacity

55 Pound Capacity

Starting Serial No. 0602004144

Refer to Page 3 for Model Numbers

— **Operation/Maintenance** —

Keep These Instructions for Future Reference.

(If this machine changes ownership, this manual must accompany machine.)



www.comlaundry.com

Part No. 70400001ENR9
July 2012

Installation must conform with local codes or in the absence of local codes with:

In the U.S.A., installation must conform to the latest edition of the American National Standard Z223.1/ NFPA 54 “National Fuel Gas Code” and Standard ANSI/NFPA 70 “National Electric Code.”

In Canada, installation must comply with Standards CAN/CSA-B149.1 or Natural Gas and Propane Code CSA C22.1, latest edition, Canadian Electric Code, Part I.

In Australia, installation must comply with the Australian Gas Association Installation Code for Gas Burning Appliances and Equipment.

	WARNING
<p>FOR YOUR SAFETY, the information in this manual must be followed to minimize the risk of fire or explosion or to prevent property damage, personal injury or death. W033</p> <ul style="list-style-type: none">• Do not store or use gasoline or other flammable vapors and liquids in the vicinity of this or any other appliance.• WHAT TO DO IF YOU SMELL GAS:<ul style="list-style-type: none">– Do not try to light any appliance.– Do not touch any electrical switch; do not use any phone in your building.– Clear the room, building or area of all occupants.– Immediately call your gas supplier from a neighbor’s phone. Follow the gas supplier’s instructions.– If you cannot reach your gas supplier, call the fire department.• Installation and service must be performed by a qualified installer, service agency or the gas supplier. W052	
<p>FOR YOUR SAFETY</p> <p>Do not store or use gasoline or other flammable vapors and liquids in the vicinity of this or any other appliance. W053</p>	

	MISE EN GARDE
<p>POUR VOTRE SÉCURITÉ, veuillez à bien respecter les indications de ce manuel afin de minimiser les risques d’incendie ou d’explosion ou d’écarter les dangers de dommages matériels, corporel ou de mort. W033FR</p> <ul style="list-style-type: none">• Évitez de ranger ou d’utiliser de l’essence ou tout autre liquide inflammable ou produisant des vapeurs inflammables à proximité de cet appareil ou de tout autre appareil.• PRÉCAUTIONS À PRENDRE SI VOUS SENTEZ UNE ODEUR DE GAZ :<ul style="list-style-type: none">– Ne tentez d’allumer aucune veilleuse.– Évitez tout contact avec les interrupteurs électriques; ne vous servez d’aucun téléphone de votre édifice.– Évacuez toute personne du local, de l’édifice ou de la zone concerné(e).– Téléphonez immédiatement à votre fournisseur du gaz en vous servant du téléphone d’un voisin. Suivez les instructions du fournisseur du gaz.– Si vous n’arrivez pas à vous mettre en contact avec votre fournisseur du gaz, appelez les pompiers.• L’installation et l’entretien de cet appareil doivent être exécutés par un installateur qualifié, un centre de service agréé ou votre fournisseur du gaz. W052FR	
<p>POUR VOTRE SÉCURITÉ</p> <p>Ne pas entreposer ni utiliser d’essence ou autres gaz et liquides inflammables au voisinage de cet appareil ou de tout autre. W053FR</p>	

IMPORTANT: Information must be obtained from a local gas supplier on instructions to be followed if the user smells gas. These instructions must be posted in a prominent location. Step-by-step instructions of the above safety information must be posted in a prominent location near the tumble dryer for customer use.

Table of Contents

Introduction	3
Model Identification	3
Customer Service.....	4
Serial Plate Location.....	4
Wiring Diagram	4
Safety Information	5
Explanation of Safety Messages.....	5
Important Safety Instructions	6
Operating Instructions	8
Emergency Stop Button on CE Models.....	8
Operating Instructions	8
LED OPL Control	9
Dual Digital Timer Control.....	10
Single Drop Control.....	12
DX4 Coin Control.....	14
DX4 OPL Control	15
Diagnostic Microprocessor Control.....	16
DMP OPL Models	17
DMP Coin	19
Ignition Control Operation for Non-CE Models	22
Ignition Control Operation for CE Models.....	23
Maintenance	25
Daily	25
Monthly.....	27
Quarterly	27
Bi-Annually	27
Annually	27
Before You Call for Service	31
Customer Service.....	31

© Copyright 2012, Alliance Laundry Systems LLC

All rights reserved. No part of the contents of this book may be reproduced or transmitted in any form or by any means without the expressed written consent of the publisher.

Introduction

Model Identification

Information in this manual is applicable to these models:

	Gas		Steam	Electric
25 Pound	CHD25G2-CA025L CHD25G2-CA025N CHD25G2-CT025L CHD25G2-CT025N CHD25G2-CU025L CHD25G2-CU025N DR25G2-BA025L	DR25G2-BA025N DR25G2-BT025L DR25G2-BT025N DR25G2-BU025L DR25G2-BU025N IPD25G2-IT025L IPD25G2-IT025N	CHD25S2-CT025S CHD25S2-CU025S DR25S2-BT025S DR25S2-BU025S IPD25S2-IT025S	CHD25E2-CT025E CHD25E2-CU025E DR25E2-BT025E DR25E2-BU025E IPD25E2-IT025E
30 Pound	CHD30G2-CA030L CHD30G2-CA030N CHD30G2-CT030L CHD30G2-CT030N CHD30G2-CU030L CHD30G2-CU030N DR30G2-BA030L DR30G2-BA030N	DR30G2-BT030D DR30G2-BT030L DR30G2-BT030N DR30G2-BU030L DR30G2-BU030N IPD30G2-IT030L IPD30G2-IT030N	CHD30S2-CT030S CHD30S2-CU030S DR30S2-BT030S DR30S2-BU030S IPD30S2-IT030S	CHD30E2-CT030E CHD30E2-CU030E DR30E2-BT030E DR30E2-BU030E IPD30E2-IT030E
35 Pound	CHD35G2-CA035L CHD35G2-CA035N CHD35G2-CT035L CHD35G2-CT035N CHD35G2-CU035L CHD35G2-CU035N DR35G2-BA035L	DR35G2-BA035N DR35G2-BT035L DR35G2-BT035N DR35G2-BU035L DR35G2-BU035N IPD35G2-IT035L IPD35G2-IT035N	CHD35S2-CT035S CHD35S2-CU035S DR35S2-BT035S DR35S2-BU035S IPD35S2-IT035S	CHD35E2-CT035E CHD35E2-CU035E DR35E2-BT035E DR35E2-BU035E IPD35E2-IT035E
55 Pound	CA055L CA055N CT055L CT055N CU055L CU055N DR55SG2-BA055L DR55SG2-BA055N	DR55SG2-BT055D DR55SG2-BT055L DR55SG2-BT055N DR55SG2-BU055L DR55SG2-BU055N IPD55G2-IT055L IPD55G2-IT055N	Not Applicable	CT055E CU055E DR55SE2-BT055E DR55SE2-BU055E IPD55E2-IT055E

Includes the following control suffixes:

3B – reversing DX4 vended	DO – DMP OPL	R3 – reversing DX4 OPL
3O – DX4 OPL	DV – DMP vended	RE – reversing LED OPL
3V – DX4 vended	DX – DMP prep for coin	RQ – reversing dual digital timer
3W – reversing DX4 prep for coin	EO – LED OPL	SD – single drop
3X – DX4 prep for coin	QT – dual digital timer	SX – single drop, prep for coin

Introduction

Customer Service

If literature or replacement parts are required, contact the source from which the machine was purchased or contact Alliance Laundry Systems at (920) 748-3950 for the name and address of the nearest authorized parts distributor.

For technical assistance, call (920) 748-3121.

Serial Plate Location

Model and serial numbers are found on serial plate on rear of machine, and inside the loading door hinge.

Refer to *Figure 1*.

Wiring Diagram

The wiring diagram is located inside the junction or contactor box. The wiring diagram part number is in the lower portion of the electrical data on the serial plate.

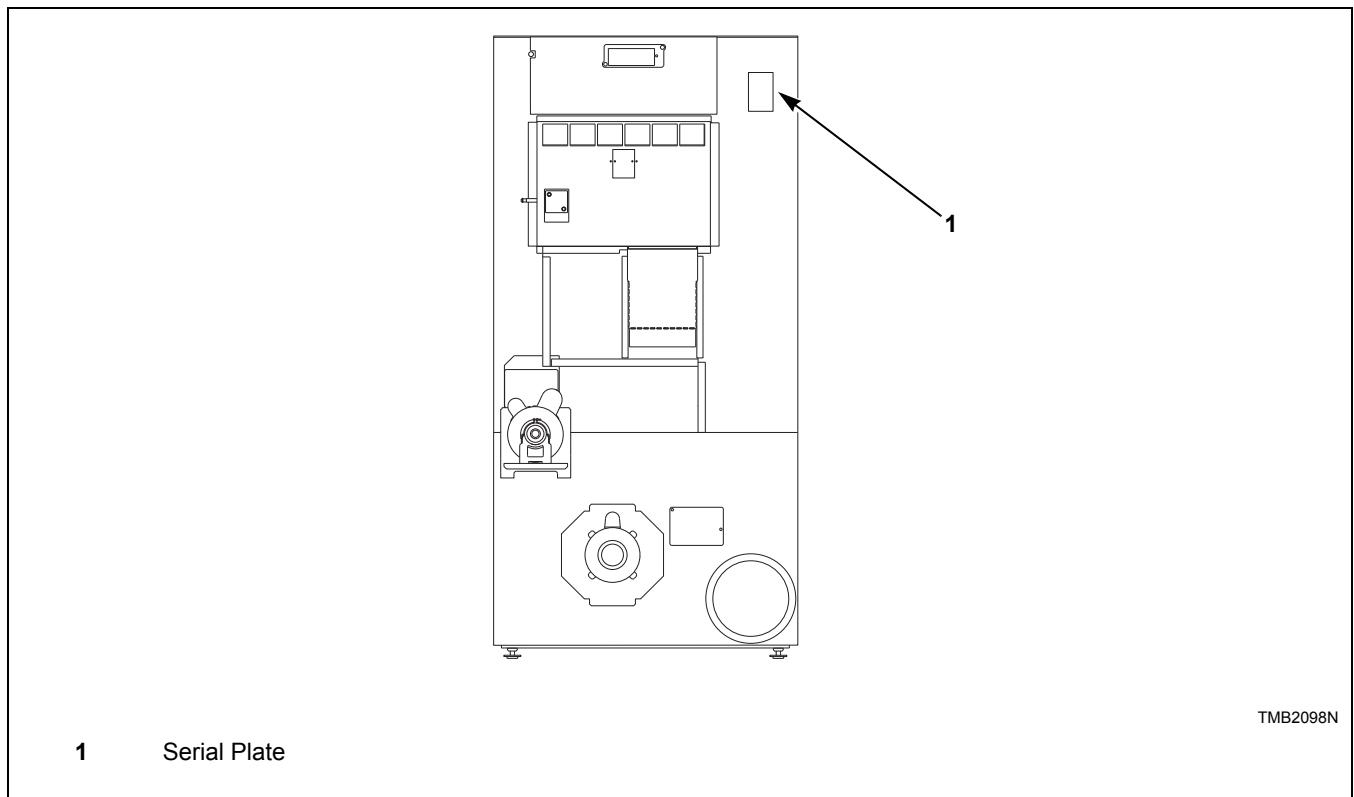



Figure 1

Safety Information

Explanation of Safety Messages

Precautionary statements (“DANGER,” “WARNING,” and “CAUTION”) followed by specific instructions, are found in this manual and on machine decals. These precautions are intended for the personal safety of the operator, user, servicer, and those maintaining the machine.

	DANGER
Indicates an imminently hazardous situation that, if not avoided, will cause severe personal injury or death.	

	WARNING
Indicates a hazardous situation that, if not avoided, could cause severe personal injury or death.	

	CAUTION
Indicates a hazardous situation that, if not avoided, may cause minor or moderate personal injury or property damage.	

Additional precautionary statements (“IMPORTANT” and “NOTE”) are followed by specific instructions.

IMPORTANT: The word “IMPORTANT” is used to inform the reader of specific procedures where minor machine damage will occur if the procedure is not followed.

NOTE: The word “NOTE” is used to communicate installation, operation, maintenance or servicing information that is important but not hazard related.

IMPORTANT: Warranty is void unless tumble dryer is installed according to instructions in the *Installation Manual*. Compliance with minimum specifications and requirements detailed herein, and with applicable local gas fitting regulations, municipal building codes, water supply regulations, electrical wiring regulations, and any other relevant statutory regulations. Because of varied requirements, applicable local codes should be thoroughly understood and all pre-installation work arranged for accordingly.

	WARNING
Failure to install, maintain, and/or operate this machine according to manufacturer’s instructions may result in conditions which can produce serious injury, death and/or property damage.	
W051R1	

NOTE: The WARNING and IMPORTANT instructions appearing in this manual are not meant to cover all possible conditions and situations that may occur. It must be understood that common sense, caution and carefulness are factors which CANNOT be built into this tumble dryer. These factors MUST BE supplied by the person(s) installing, maintaining or operating the tumble dryer.

Always contact your dealer, distributor, service agent or the manufacturer on any problems or conditions you do not understand.

Safety Information

Important Safety Instructions

Save These Instructions

	WARNING
Hazardous Voltage. Can cause shock, burn or cause death. Allow machine power to remain off for two minutes prior to working in and around AC inverter drive.	
W359	

1. Read all instructions before using the tumble dryer.
2. Refer to the **GROUNDING INSTRUCTIONS** for the proper grounding of the tumble dryer.
3. Do not dry articles that have been previously cleaned in, washed in, soaked in, or spotted with gasoline, dry cleaning solvents, other flammable or explosive substances as they give off vapors that could ignite or explode.
4. Do not allow children on or in the tumble dryer. This appliance is not intended for use by young children or infirm persons without supervision. Young children should be supervised to ensure that they do not play with the appliance.
5. Before the tumble dryer is removed from service or discarded, remove the door to the drying compartment and the door to the lint compartment.
6. Do not reach into the tumble dryer if the cylinder is revolving.
7. Do not install or store the tumble dryer where it will be exposed to water and/or weather.
8. Do not tamper with the controls.
9. Do not repair or replace any part of the tumble dryer, or attempt any servicing unless specifically recommended in the user-maintenance instructions or in published user-repair instructions that you understand and have the skills to carry out.
10. Do not use fabric softeners or products to eliminate static unless recommended by the manufacturer of the fabric softener or product.
11. To reduce the risk of fire, **DO NOT DRY** plastics or articles containing foam rubber or similarly textured rubberlike materials.
12. Always clean the lint filter daily.
13. Keep area around the exhaust opening and adjacent surrounding area free from the accumulation of lint, dust and dirt.
14. The interior of the tumble dryer and the exhaust duct should be cleaned periodically by qualified service personnel.
15. If not installed, operated and maintained in accordance with the manufacturer's instructions or if there is damage to or mishandling of this product's components, use of this product could expose you to substances in the fuel or from fuel combustion which can cause death or serious illness and which are known to the State of California to cause cancer, birth defects or other reproductive harm.
16. Tumble dryer will not operate with the loading door open. **DO NOT** bypass the door safety switch to permit the tumble dryer to operate with the door open. The tumble dryer will stop tumbling when the door is opened. Do not use the tumble dryer if it does not stop tumbling when the door is opened or starts tumbling without pressing or turning the START mechanism. Remove the tumble dryer from use and call for service.
17. Tumble dryer will not operate with lint panel open. **DO NOT** bypass lint panel safety switch to permit the tumble dryer to operate with the lint panel open.
18. Do not put articles soiled with vegetable or cooking oil in the tumble dryer, as these oils may not be removed during washing. Due to the remaining oil, the fabric may catch on fire by itself.
19. To reduce the risk of fire, **DO NOT** put clothes which have traces of any flammable substances such as machine oil, flammable chemicals, thinner, etc. or anything containing wax or chemicals such as in mops and cleaning cloths, or anything dry-cleaned at home with dry-cleaning solvent in the tumble dryer.
20. Use the tumble dryer only for its intended purpose, drying fabrics.
21. **ALWAYS** disconnect and lockout the electrical power to the tumble dryer before servicing. Disconnect power by shutting off appropriate breaker or fuse.
22. Install this tumble dryer according to the **INSTALLATION INSTRUCTIONS**. All connections for electrical power, grounding, and gas supply must comply with local codes and be made by licensed personnel when required.

Safety Information

23. Remove laundry immediately after tumble dryer stops.
24. Always read and follow manufacturer's instructions on packages of laundry and cleaning aids. Heed all warnings or precautions. To reduce the risk of poisoning or chemical burns, keep them out of reach of children at all times (preferably in a locked cabinet).
25. Do not tumble fiberglass curtains and draperies unless the label says it can be done. If they are dried, wipe out the cylinder with a damp cloth to remove particles of fiberglass.
26. Always follow the fabric care instructions supplied by the garment manufacturer.
27. Never operate the tumble dryer with any guards and/or panels removed.
28. **DO NOT** operate the tumble dryer if it is smoking, grinding, has missing or broken parts.
29. **DO NOT** bypass any safety devices.
30. Solvent vapors from dry-cleaning machines create acids when drawn through the heater of the drying unit. These acids are corrosive to the tumble dryer as well as to the laundry load being dried. Be sure make-up air is free of solvent vapors.
31. Failure to install, maintain, and/or operate this machine according to the manufacturer's instructions may result in conditions which can produce bodily injury and/or property damage.



WARNING

To reduce the risk of serious injury, install lockable door(s) to prevent public access to rear of tumble dryers.

W055R1

Operating Instructions



WARNING

To reduce the risk of fire:

- DO NOT DRY articles containing foam rubber or similarly textured rubberlike materials.
- DO NOT DRY plastics, anything containing wax or chemicals such as mops and cleaning cloths, or anything dry-cleaned at home with a dry-cleaning solvent.
- DO NOT TUMBLE fiberglass curtains and draperies unless the label says it can be done. If they are dried, wipe out the cylinder with a damp cloth to remove particles of fiberglass.

W076

To reduce the risk of serious injury, allow cylinder to stop before cleaning lint screen.

W412

Emergency Stop Button on CE Models

All CE approved OPL Tumble Dryers are factory equipped with an emergency stop button located on the front panel. Refer to *Figure 2*.

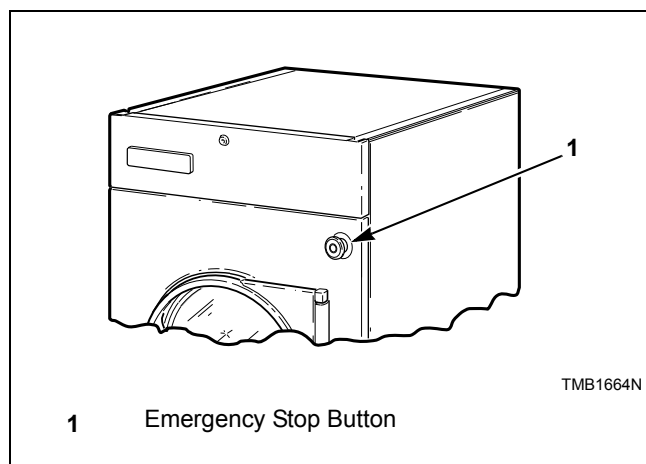

Figure 2

To operate emergency stop button:

- a. Press red emergency stop button to stop all action.
- b. To restart machine, pull red emergency stop button out and press START pad or button.

NOTE: Activation of the emergency stop button stops all machine control circuit functions, but DOES NOT remove all electrical power from machine.

Operating Instructions

Step 1: Clean Lint Screen/Compartment

Remove any accumulated lint from the lint screen and compartment. Close panel tightly against tumble dryer frame and lock panel securely, if applicable.

IMPORTANT: Clean lint screen and lint compartment daily. Failure to clean the lint screen daily will result in higher than normal temperatures that may damage laundry.

Step 2: Load Laundry

Open loading door and load cylinder with laundry. DO NOT OVERLOAD.

NOTE: Overloading causes slow drying and wrinkling.

Close loading door. Tumble dryer will not operate with the door open.

Step 3: Determine Control Type and Temperature Setting

Refer to the various controls and follow the instructions for the appropriate control type.

The type of fabric being dried will determine the temperature setting. Consult the fabric care label or fabric manufacturer to determine proper temperature setting.

IMPORTANT: Always follow the fabric care instructions supplied by the garment manufacturer.

Step 4: Remove Laundry

When the cycle is complete, open door and remove the laundry.

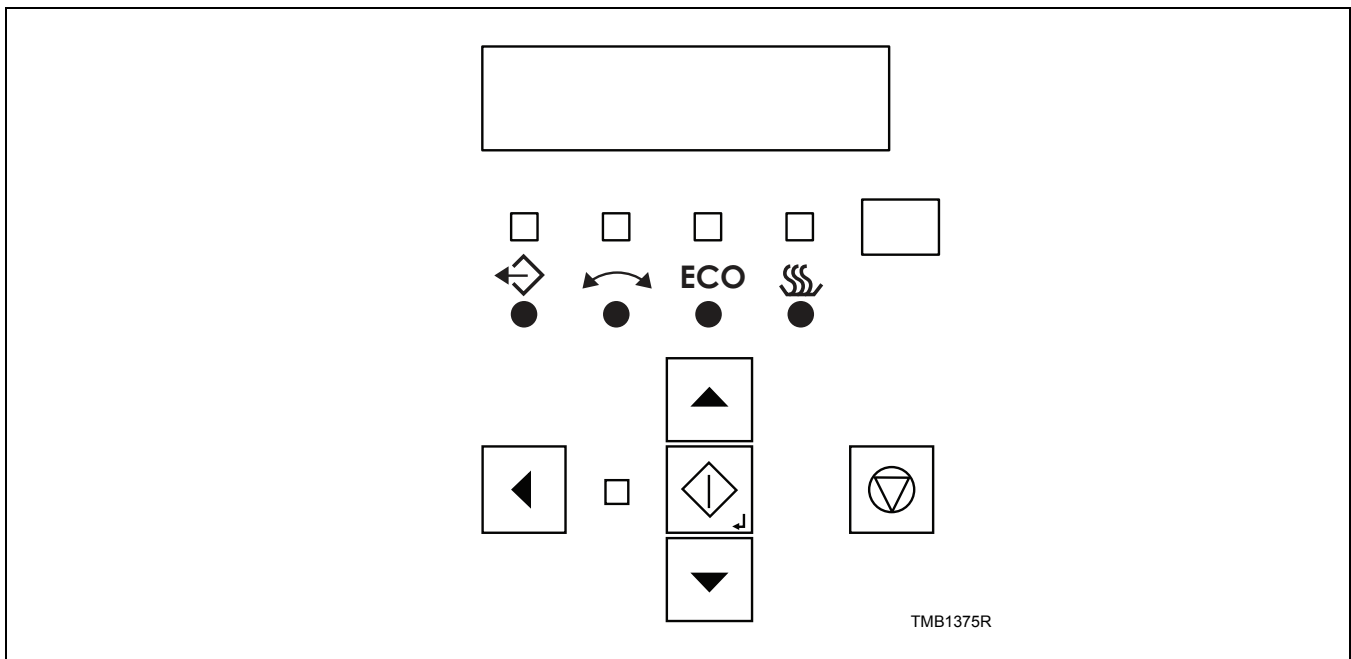

Figure 3

LED OPL Control

EO and RE Control Suffixes

1. Press the Up (▲) or Down (▼) keypad to change cycles.
To customize a cycle, refer to the *Programming Manual*.
2. Press Start (◊/↶) to start selected cycle.

IMPORTANT: If the loading door or lint panel door is opened during the cycle, the heating system will shut off and the motor will stop. To restart the cycle, both doors must be closed and the Start (◊/↶) pad must be pressed.

3. When the cycle is complete, open door and remove laundry.

NOTE: This machine includes an anti-wrinkle/extended tumble feature. After the drying cycle is complete, the cylinder will tumble without heat every few minutes. The intermittent tumbling will continue for one hour or until the door is opened. After an hour the machine enters delayed tumble and will tumble for two minutes every hour for up to 18 hours or until the door is opened.

Operating Instructions

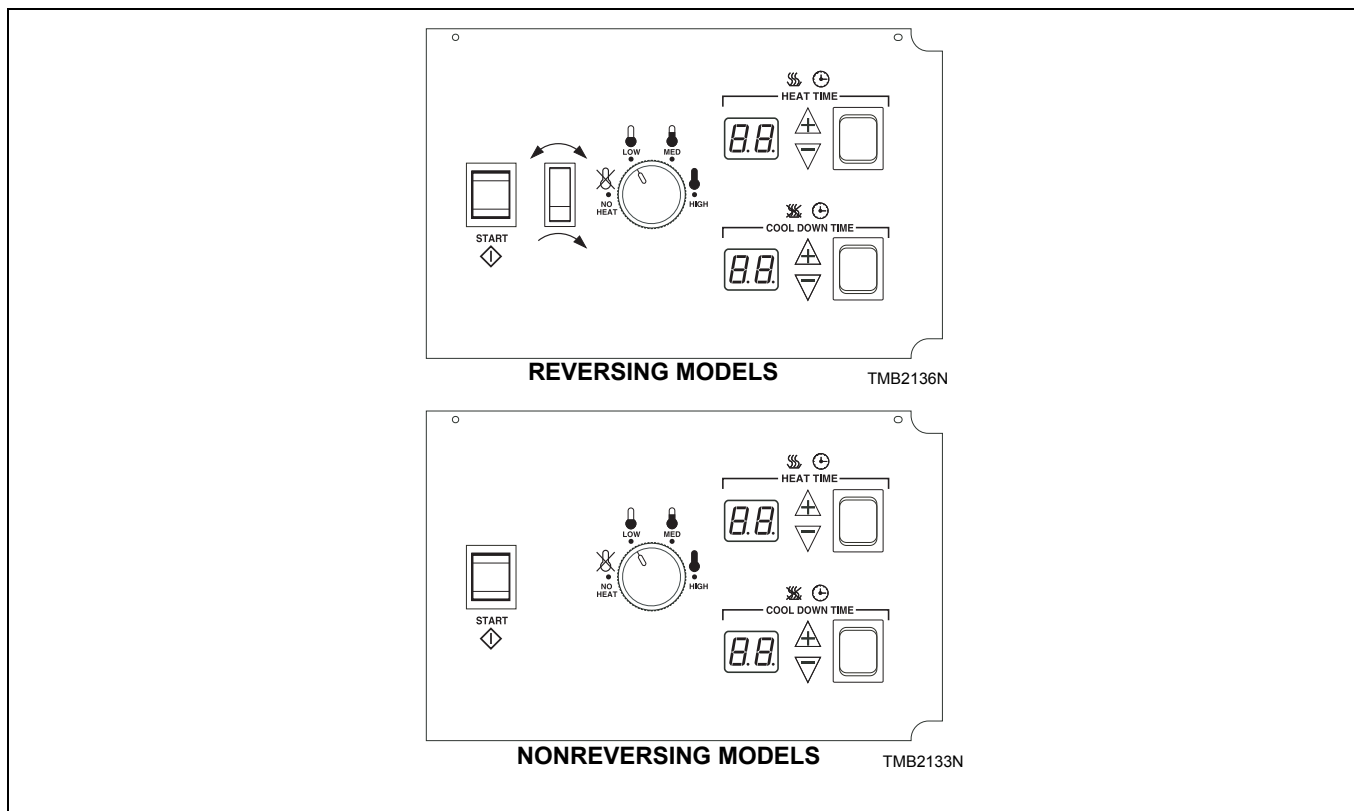

Figure 4

Dual Digital Timer Control

QT and RQ Control Suffixes

1. Select HIGH, MED, LOW or NO HEAT by turning the temperature knob.
HIGH temperature 190°F (87°C)
MED temperature 170°F (77°C)
LOW temperature 120°F (49°C)
2. Set the HEAT TIME for the number of minutes (from 0-60) desired.
3. Set the COOL DOWN TIME for the number of minutes (from 0-15) desired.
4. Select reversing or nonreversing cylinder rotation setting, if applicable.
5. Press and release START button to start tumble dryer. Display will show minutes remaining before end of cycle.

NOTE: One touch drying is available for repetitive loads. If the START button is pressed while the machine is in Idle Mode, when the display is dark, the tumble dryer will repeat the last drying cycle. If the cycle time is adjusted before the cycle is started, the time displayed when the start button was pressed will be used for future cycles.

IMPORTANT: To stop the tumble dryer at any time during the cycle, OPEN DOOR. If the loading door or lint panel door is opened during the cycle, the heating system will shut off and the motor will stop. To restart the cycle, both doors must be closed and the START button must be pressed in.

If the load cools to 90°F before cool down time expires, the control will flash “Lr” (load ready) in the heat time display. If the door is not opened, the tumble dryer completes the selected cool down time. If the door is opened after reaching “Lr” temperature, the cycle will be terminated.

NOTE: If display shows an error code, refer to Error Codes section.

6. When the cycle is complete, open door and remove the laundry. Anti-wrinkle feature will tumble the load without heat for 30 seconds every 2 minutes for 1 hour OR until the loading door is opened.

NOTE: This machine includes an anti-wrinkle/extended tumble feature. After the drying cycle is complete, the cylinder will tumble without heat every few minutes. The intermittent tumbling will continue for one hour or until the door is opened.

Error Codes

	WARNING
<p>To reduce the risk of electric shock, fire, explosion, serious injury or death:</p> <ul style="list-style-type: none"> • Disconnect electric power to the tumble dryer before servicing. • Close gas shut-off valve to gas tumble dryer before servicing. • Close steam valve to steam tumble dryer before servicing. • Never start the tumble dryer with any guards/panels removed. • Whenever ground wires are removed during servicing, these ground wires must be reconnected to ensure that the tumble dryer is properly grounded. 	
W002R1	

Display	Definition	Corrective Action
OP	Open thermistor error	<ul style="list-style-type: none"> • Check thermistor. Replace if inoperative. • Check wiring diagram between control and thermistor. Refer to wiring diagram for proper wiring. • Check control. Replace if inoperative.
SH	Shorted thermistor error	<ul style="list-style-type: none"> • Check thermistor. Replace if inoperative. • Check wiring between control and thermistor. Refer to wiring diagram for proper wiring. • Check control. Replace if inoperative.
AF - 1	Airflow switch closed when cycle started	<ul style="list-style-type: none"> • Check airflow switch. Replace if inoperative.
AF - 2	Airflow switch failed to close after cycle started	<ul style="list-style-type: none"> • Check airflow switch. Replace if inoperative.
AF (Flashing)	Bouncing Airflow Switch	<ul style="list-style-type: none"> • Check airflow switch to ensure that it is properly aligned and securely mounted in the mounting bracket. • Make sure airflow switch can open and close freely. • Check installation and make sure there is adequate airflow. • Make sure exhaust is not blocked. • Clean the lint screen. • Replace airflow switch if inoperative.
AF (Solid)	Airflow Switch Closed when Resuming Cycle	<ul style="list-style-type: none"> • Allow up to 20 seconds for this condition to clear. • Check if airflow switch opens at end of cycle. • Replace airflow switch if inoperative.

Operating Instructions

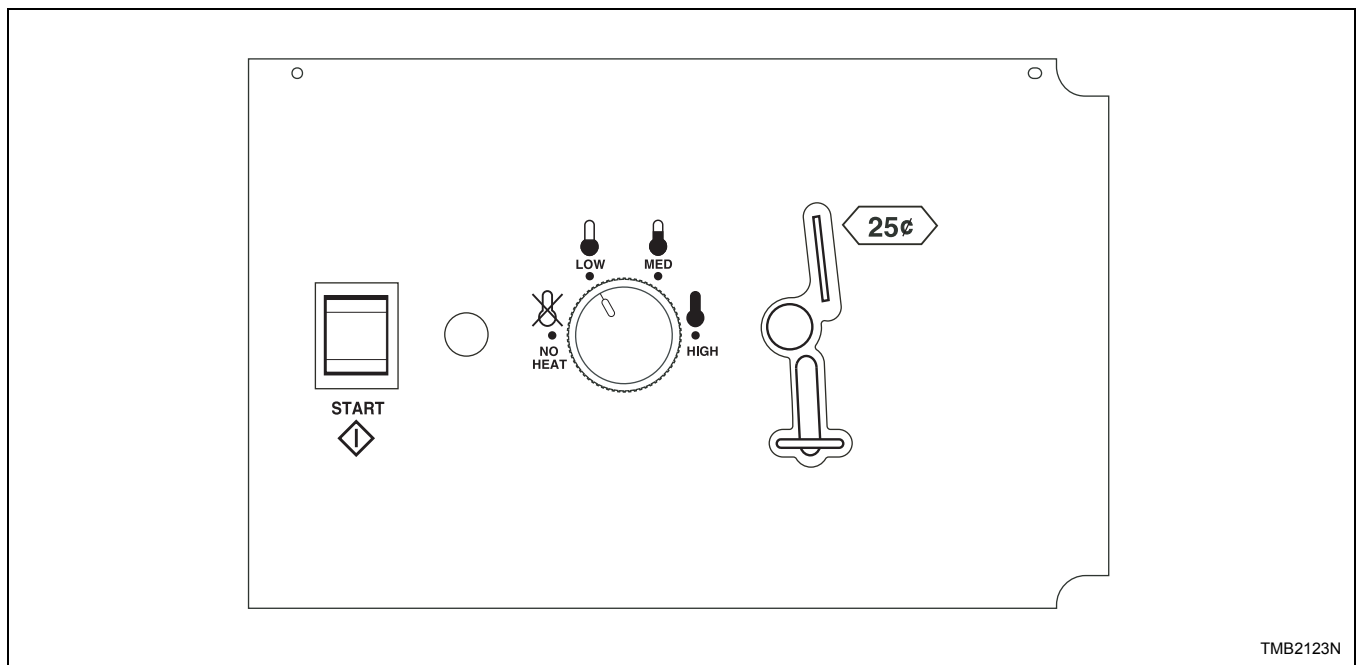

Figure 5

Single Drop Control

SD and SX Control Suffixes

1. Select HIGH, MED, LOW or NO HEAT by turning the temperature knob.
HIGH temperature 190°F (87°C)
MED temperature 160°F (71°C)
LOW temperature 130°F (54°C)
2. Insert the coin(s) in the coin slot.
3. Press START button to start tumble dryer.

IMPORTANT: To stop the tumble dryer at any time during the cycle, OPEN DOOR. To restart the tumble dryer, CLOSE door and press START button.

NOTE: If display show an error code, refer to Error Codes section.

4. When the cycle is complete, open door and remove the laundry.

NOTE: This machine includes an extended tumble feature. Starting 20 minutes after a cycle ends, the cylinder will tumble for two minutes every hour without heat, up to 18 hours or until door is opened.

Preliminary Control Information

Power-Up Mode

When power is applied to the tumble dryer the control will enter Ready Mode, unless a cycle was in process prior to a disruption of power. If a power disruption is less than 5 seconds, with a cycle in process, the control will enter Run Mode once power is restored and continue the cycle. If a power disruption is more than 5 seconds, with a cycle in process, the control will enter Start Mode once power is restored.

If the dry time dipswitch settings have not changed from the factory default, the *IN USE* LED will flash two to five times, depending on model.

Ready Mode

In Ready Mode, the control waits for the vend to be satisfied before entering Start Mode.

Start Mode

In Start Mode, the vend has been satisfied, but the Start button has not been pressed. The *IN USE* LED will be lit. The timer will not count down until the Start button is pressed.

Run Mode

In Run Mode, the control is running a cycle. The *IN USE* LED is lit.

Door Open Mode

In Door Open Mode, the control turns off the heater and motor when the door is opened during a run cycle. The timer will continue to count down time and the *IN USE LED* is lit.

End of Cycle Mode

In End of Cycle Mode, a cycle is complete and the *IN USE LED* is off. The control remains in this mode until the door is opened or additional vend has been satisfied.

Topoffs

Any time the control receives a coin drop pulse during a cycle it will add the programmed dry time to the time currently remaining in the cycle. The maximum cycle time is 99 minutes, the control will not add time beyond 99 minutes. The cool down time will not change.

If the control receives a coin drop pulse during cool down the *IN USE LED* will flash briefly to indicate the coin input, the machine will exit cool down and it will start heating. The cycle time will be equal to the programmed dry time.

Temperature Selector Switch

For five minutes after the control is powered up, there is a diagnostic feature that allows the temperature selector switches to be tested.

When the temperature selector is changed, the new setting is displayed by flashing the *IN USE LED* as follows:

- High/Normal: 4 flashes
- Medium/PP: 3 flashes
- Low/Delicate: 2 flashes
- No Heat: 1 flash

Error Codes

	WARNING
<p>To reduce the risk of electric shock, fire, explosion, serious injury or death:</p> <ul style="list-style-type: none"> • Disconnect electric power to the tumble dryer before servicing. • Close gas shut-off valve to gas tumble dryer before servicing. • Close steam valve to steam tumble dryer before servicing. • Never start the tumble dryer with any guards/panels removed. • Whenever ground wires are removed during servicing, these ground wires must be reconnected to ensure that the tumble dryer is properly grounded. 	
W002R1	

Display	Definition	Corrective Action
AF (flashing)	Airflow switch opened/closed 5 or more times in a running cycle.	<ul style="list-style-type: none"> • Check airflow switch. Replace if inoperative.

NOTE: To change dipswitch settings refer to *Installation Manual*.

To Program a Short Test Cycle:

1. Unplug machine power cord.
2. Write down machine control dip switch settings, then set them all to the off position. Refer to *Figure 6*.
3. Plug machine in and start a cycle.

NOTE: With all control dip switches off, the total cycle time will be 2 minutes long (1 minute of heat and 1 minute of cool down).

4. Once all testing is complete, unplug machine and re-set dip switches to their original settings.
5. Plug machine in.

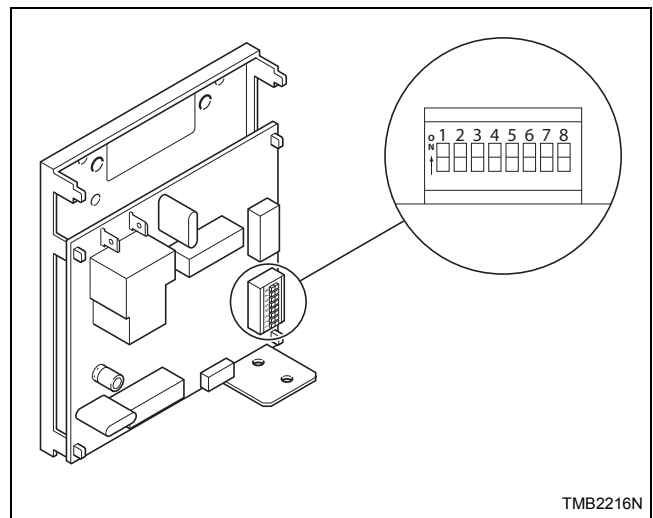

Figure 6

TMB2216N

Operating Instructions

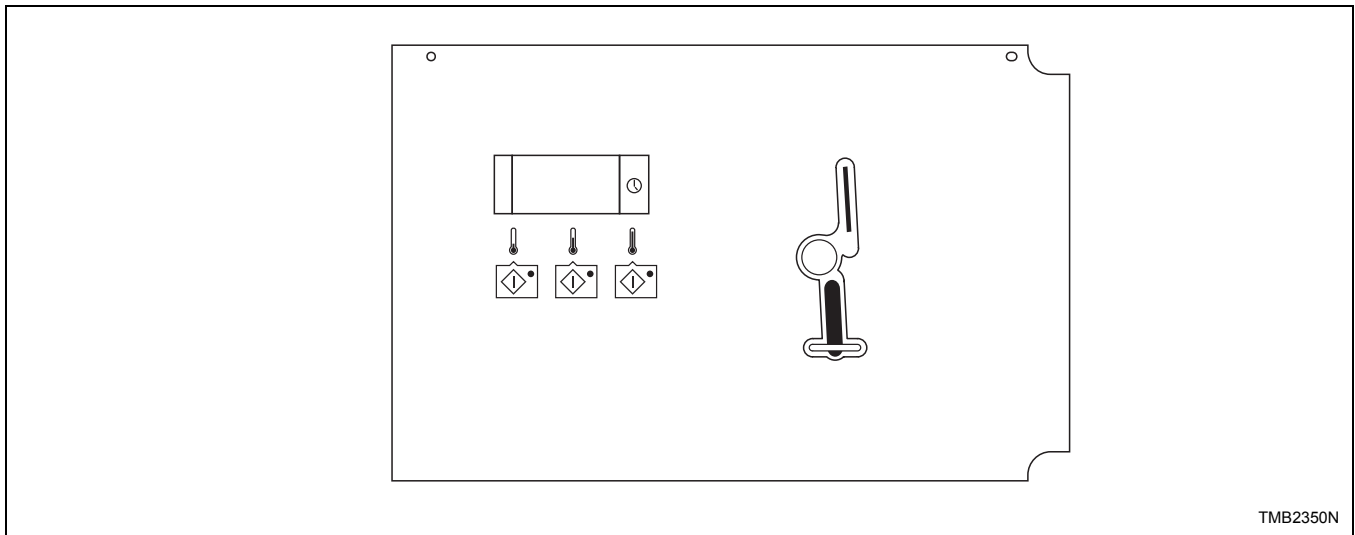

Figure 7

DX4 Coin Control

3B, 3V, 3W and 3X Control Suffixes

1. Open door and fill drum with clothes.
2. Close door.
3. Insert the coin(s) in the coin slot.
4. Press and release one of the cycle buttons to select a cycle and start the tumble dryer. Refer to *Table 1*.

To use a custom cycle, refer to the *Programming Manual*.

NOTE: Drying times will be dependent on the number of coins that are inserted in the coin slot.

IMPORTANT: To stop the tumble dryer at any time during the cycle, **OPEN DOOR**. To restart the tumble dryer, **CLOSE door and press START button**.

5. When the cycle is complete, open door and remove the laundry.

	Temperature	Drying Time	Cool Down Time
Left Button	104°F (40°C)	Varies	2 min.
Middle Button	140°F (60°C)	Varies	2 min.
Right Button	176°F (80°C)	Varies	2 min.

Table 1

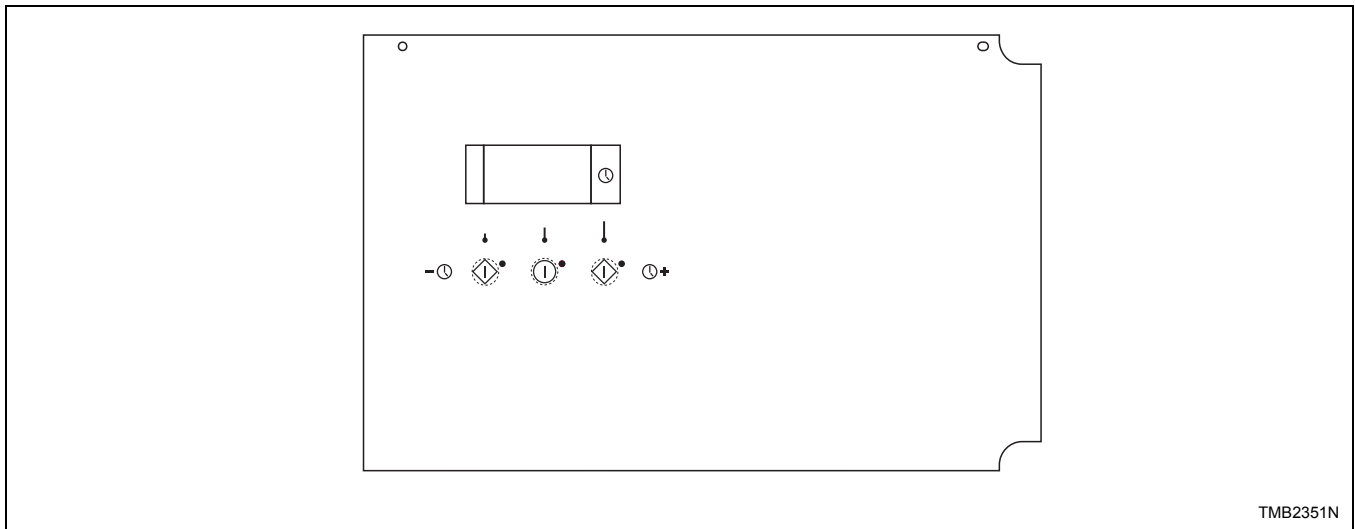

TMB2351N

Figure 8

DX4 OPL Control

30 and R3 Control Suffixes

1. Open door and fill drum with clothes.
2. Press and release one of the cycle buttons to select a cycle and start the tumble dryer. Refer to *Table 2*.

To use a custom cycle, refer to the *Programming Manual*.

IMPORTANT: To stop the tumble dryer at any time during the cycle, **OPEN DOOR**. To restart the tumble dryer, **CLOSE door and press START button**.

3. When the cycle is complete, open door and remove the laundry.

	Temperature	Drying Time	Cool Down Time
Left Button	104°F (40°C)	30 min.	2 min.
Middle Button	140°F (60°C)	30 min.	2 min.
Right Button	176°F (80°C)	35 min.	2 min.

Table 2

Operating Instructions

Diagnostic Microprocessor Control

General Operation

The Diagnostic Microprocessor Control (DMP) is designed to manage the drying and cooling cycles of the tumble dryer. The controller is also programmed from the factory with five different default programs as described below. The operator has the flexibility to select the time for the drying and the cool down cycles and the drying temperature. The operator may also reprogram the default programs.

Default Programs

Programs	Dry Time (Min.)	Cool Time (Min.)	Temp. Set Point
1 – Towels	40	5	185°/195°F (85°/91°C)
2 – Sheets	30	5	165°F (74°C)
3 – Misc-1	30	5	150°F (66°C)
4 – Misc-2	25	5	135°F (57°C)
5 – Extra Dry	5	2	150°F (66°C)

NOTE: If an altered program is determined to be corrupted, the default program settings will be used.

Table 3

Features

- Drying time: 0-60 minutes
- Cooling time: 2-60 minutes
- LED display of cycle time, set temperature, and actual temperature
- Thermistor controlled temperature
- Safety tumble cycle
- Buzzer for end of cycle, audible alarm
- Five user programmable programs
- RPM display – when equipped with rotational sensor only
- Monitors the lint door switch operation
- Monitors the thermistor for operation

The minimum drying time is 0 minutes, and the minimum cooling time is 2 minutes. The maximum drying or cooling time is 60 minutes. The drying temperature may be set from 100°F (38°C) to 185°/195°F (85°/91°C). The drying time, cooling time, or temperature may be modified during an operating cycle.

If it is necessary to reset the drying and cooling times for the current cycle, press STOP once to stop the tumble dryer. Press STOP again to cancel the cycle.

If it is necessary to change programs during a current cycle, press STOP once to stop the tumble dryer and press STOP again to cancel the current cycle.

DMP OPL Models

DO Control Suffix

Description of the OPL Control Panel

Refer to *Figure 9*.

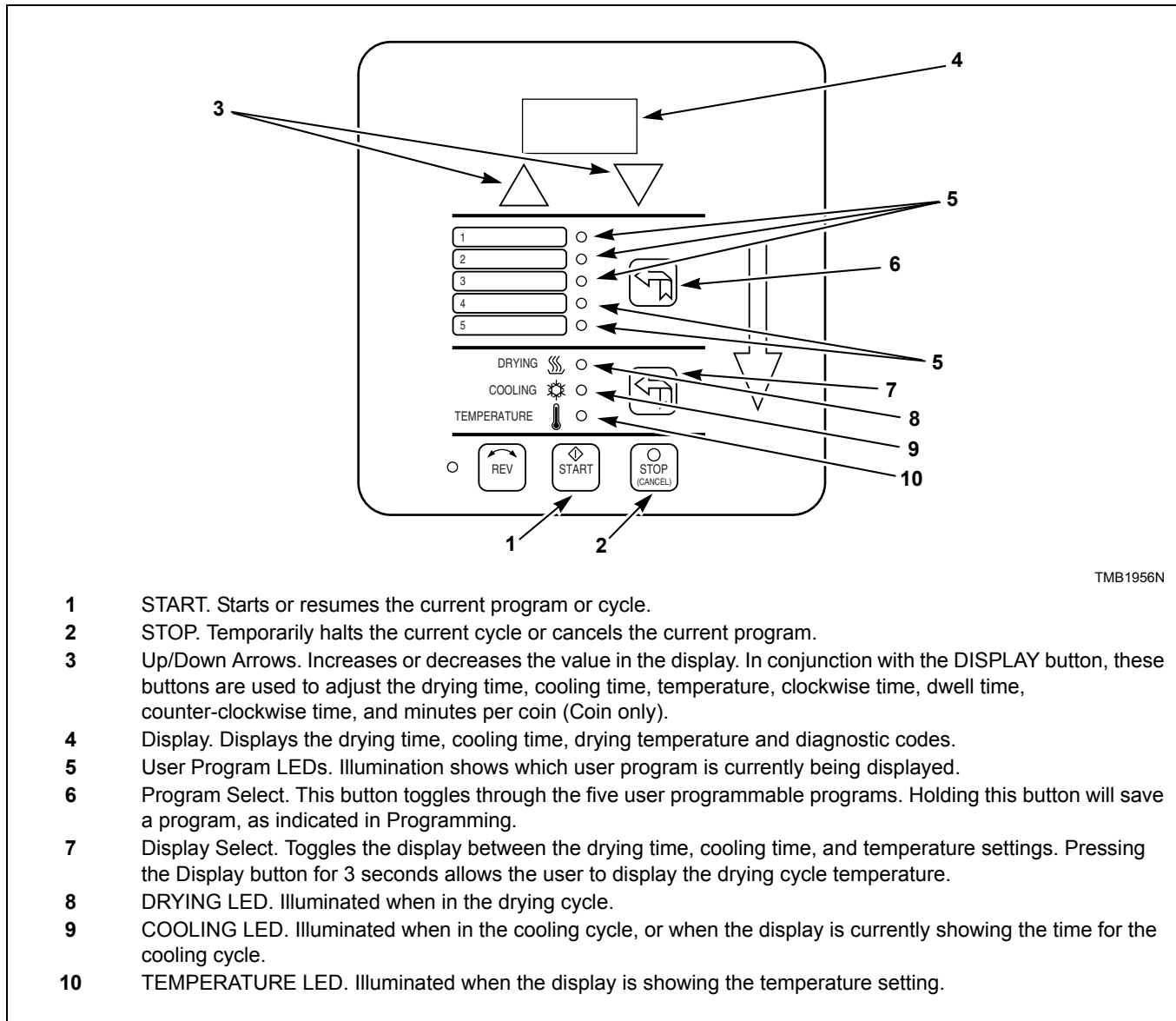

- 1** START. Starts or resumes the current program or cycle.
- 2** STOP. Temporarily halts the current cycle or cancels the current program.
- 3** Up/Down Arrows. Increases or decreases the value in the display. In conjunction with the DISPLAY button, these buttons are used to adjust the drying time, cooling time, temperature, clockwise time, dwell time, counter-clockwise time, and minutes per coin (Coin only).
- 4** Display. Displays the drying time, cooling time, drying temperature and diagnostic codes.
- 5** User Program LEDs. Illumination shows which user program is currently being displayed.
- 6** Program Select. This button toggles through the five user programmable programs. Holding this button will save a program, as indicated in Programming.
- 7** Display Select. Toggles the display between the drying time, cooling time, and temperature settings. Pressing the Display button for 3 seconds allows the user to display the drying cycle temperature.
- 8** DRYING LED. Illuminated when in the drying cycle.
- 9** COOLING LED. Illuminated when in the cooling cycle, or when the display is currently showing the time for the cooling cycle.
- 10** TEMPERATURE LED. Illuminated when the display is showing the temperature setting.

Figure 9

Operating Instructions

DMP OPL Features

DIP Switch Settings

The DMP has an 8 position DIP switch bank that is accessible from the back of the control board. By switching these DIP switches, it is possible for the operator to customize the display and some of the operating features of the tumble dryer.

Dip Switch	Funtion		
1	Tumble Dryer Type	ON – Coin OFF – OPL	
2	Temperature Units	ON – C OFF* – F	
3	Local or Remote Reversing	ON* – Local Reversing OFF – Remote Reversing	
4	Empty	ON*	
5	Empty	ON*	
6	Buzzer Timer	ON – Continuous OFF – 5 Sec	
7	OPL Models - Safety Tumble	Dip Switch	
		#1	#7
		OFF	ON
	Coin Models - Coin Count/Pay	Dip Switch	
		#1	#7
		ON	ON
	ON	OFF	Pay
8	Programming	ON – Enable OFF* – Disable	

* Factory default setting

Table 4

DIP Switch Functions Explained

1. Tumble dryer Type: This DIP switch selects the type of tumble dryer, i.e., OPL or Coin.
2. Temperature Units: Selects °F or °C for the temperature display. Factory setting is for °F.
3. Local/Remote Reversing: Preset at the factory; usually for local reversing. Remote reversing for use with Reversing Timer Board only.
4. Empty: Preset at the factory; always ON.
5. Empty: Preset at the factory; always ON.
6. Buzzer Timer: This DIP switch determines the length of time that the end of cycle buzzer will remain on. “OFF” indicates that the buzzer will sound for 5 seconds when the drying cycle is completed. “ON” indicates that the buzzer will sound continuously until the STOP button is pressed or the loading door is opened.
7. Safety Tumble (OPL) or Coin count/Pay (Coin): If DIP switch #1 is set for OPL, then DIP switch #7 in the ON position enables the safety tumble. If DIP switch #1 is set for Coin, then DIP switch #7 in the ON position enables the display of the coin count. DIP switch #7 in the OFF position enables the display of “PAY,” to indicate that coins are needed to run the tumble dryer.
8. Programming: This switch enables or disables the programming feature and should normally be in the OFF position.

DMP Coin

DV and DX Control Suffixes

Description of The Coin Control Panel

Refer to *Figure 10*.

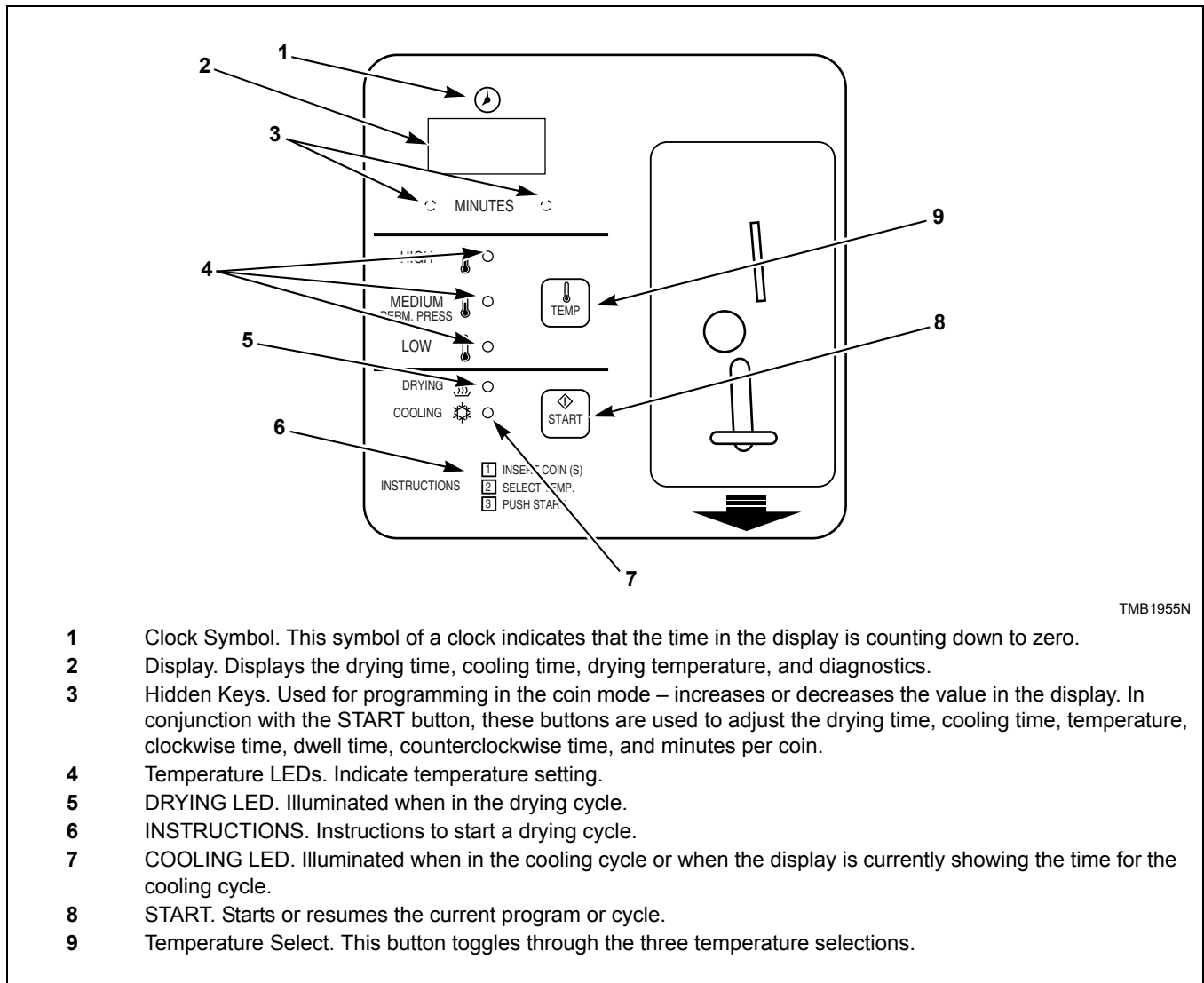

- 1 Clock Symbol. This symbol of a clock indicates that the time in the display is counting down to zero.
- 2 Display. Displays the drying time, cooling time, drying temperature, and diagnostics.
- 3 Hidden Keys. Used for programming in the coin mode – increases or decreases the value in the display. In conjunction with the START button, these buttons are used to adjust the drying time, cooling time, temperature, clockwise time, dwell time, counterclockwise time, and minutes per coin.
- 4 Temperature LEDs. Indicate temperature setting.
- 5 DRYING LED. Illuminated when in the drying cycle.
- 6 INSTRUCTIONS. Instructions to start a drying cycle.
- 7 COOLING LED. Illuminated when in the cooling cycle or when the display is currently showing the time for the cooling cycle.
- 8 START. Starts or resumes the current program or cycle.
- 9 Temperature Select. This button toggles through the three temperature selections.

Figure 10

Operating Instructions

DMP Coin Features

Coin Keypad Interface

- START button to start or resume a cycle.
- TEMP button to select HIGH, MEDIUM, or LOW temperature.
- Two hidden buttons to increment or decrement the programmable time and temperature options.

Power-Up

Upon applying power to the tumble dryer, the display will show “PAy” and the DRYING and COOLING LEDs will be off until coins are deposited to increase the tumble dryer run time. When time is displayed, the default (LOW) temperature setting LED will be on until a different temperature setting is selected.

Power Failure

If a power loss occurs during operation, a cycle will not resume until the START button is pressed. To cancel the remaining cycle, press the internal CLEAR button.

Coin Operation

The tumble dryer run time is determined by the pre-programmed run time per coin and the number of coins deposited into the tumble dryer. The maximum time that can be accumulated and displayed is 99 minutes. The drying time is the difference between the run time and the cooling time. The cooling time is pre-programmed to be 2 to 5 minutes. The drying temperature can be selected from LOW, MEDIUM, or HIGH temperature settings by pressing the TEMP button.

Coin Programming

The Coin board programming mode can only be entered when “PAy” is displayed. DIP switch #7 must be in the OFF position.

Programming is enabled by setting DIP switch #8 to the ON position.

The programming mode is entered by pressing and holding the CLEAR button for three seconds.

The programming follows the following parameter order:

1. Tumble dryer run time per coin (DRYING), COOLING time, HIGH temperature setpoint, MEDIUM temperature setpoint, LOW temperature setpoint.
2. An LED will be on to indicate which parameter is flashing on the display.
3. The hidden front panel increment and decrement keys are used to change the value.
4. The CLEAR button is used to recall the default value.
5. The START button is used to step to the next parameter.
6. After the last parameter, “End” will be flashing.
7. Press the START button one last time to store the settings and exit the program mode.
8. “PAy” will be displayed.
9. If it is determined that the data did not program correctly, the error message “E2F” will flash for 4 seconds, and then the default coin parameters will be used.

The tumble dryer run time per coin is programmable for 1 to 20 minutes with the default preset to 10 minutes.

The cooling run time is programmable from 2 to 5 minutes with the default preset to 2 minutes.

The three temperatures setpoints are programmable for 100°F (38°C) to 185°/195°F (85°/90°C) with the following default settings:

- HIGH equal to 185°F (85°C)
- MEDIUM equal to 150°F (66°C)
- LOW equal to 135°F (57°C)

Stop

When in the Coin mode, the tumble dryer will stop if the tumble dryer door is opened while the tumble dryer is running. If the CLEAR button, located behind the board, is pressed, the tumble dryer will stop, the tumble dryer time will be zeroed and the display will show “PAy.”

Coin Count

The unit will count the number of coins deposited.

Setting DIP switch #7 to the ON position will display the coin count since it was the last reset.

To reset the count, press the CLEAR button and “00” will be displayed.

If the coin count is greater than “999,” the display will flash “999.”

Setting DIP switch #7 to the OFF position will return the display to “PAy.”

Programming

1. Set DIP switch #8 to the ON position.
2. Select the desired program number to change. The LED should be flashing.
3. Select DRY TIME. Set the time with the Up/Down arrows.
4. Select COOL TIME. Set the time with the Up/Down arrows.
5. Select TEMPERATURE. Set the temperature with the Up/Down arrows.
6. Press and hold the Program Select button about 3 seconds until the LED stops flashing. The selected program number is now programmed. If the Program button is pressed for less than 3 seconds, the controller will cancel the program and display the next program's settings. If not programmed correctly, the display will flash "E2F" for 4 seconds, and the default settings will be used. Follow steps 4 through 7 to reprogram any program number. When finished, set DIP switch #8 to OFF. The programs are now stored.
7. During the Program Mode, if the Up/Down arrows or Display button is not pressed within 10 seconds, the default program settings will be used.
8. Temporary Reprogramming of Current Programs (OPL ONLY).
9. The Drying Time, Cooling Time and Temperature of a program currently in use may be modified simply by adjusting any or all of the program parameters for that program, as needed. Once a modification has been made, the current program LED will flash indicating that it has been modified.
10. Use the Up/Down arrows to adjust program time.
11. Use the Display Select button to choose between Drying Time, Cooling Time, and Temperature. Then use the Up/Down arrows to adjust the times and temperature.
12. To cancel this temporary programming mode push the STOP button once to stop the current cycle and once more to cancel the modified program settings. The program will revert back to its original settings.

Rotation Sensor

The rotation sensor must "read" the key on the basket shaft or pulley. The sensor must be set approximately 1/4 inch from the key or pulley. Look for the light on the sensor to come on as the key passes the sensor; this is a correctly operating sensor. If no light appears, either the sensor is out of range or the key/pulley or the sensor is bad. In addition, if the light stays on continuously, then the sensor is too close to the component or the sensor is bad.

Safety Tumble/Anti-Wrinkle

At the end of the cool down cycle, the tumble dryer will stop and display "END." The DMP control will automatically rotate the basket for 5 seconds every 2 minutes for a total of 20 minutes, until some function of the tumble dryer is activated/deactivated by the user.

Operational Check for the Board Diagnostics

1. "dor" indicates that the loading or lint door is open.
2. Cycle the tumble dryer to check if the buzzer activates.
3. "P-F" indicates that the thermistor is short circuited or open circuited.
4. "bbt" indicates a broken belt condition or a faulty rotation sensor. (Only available on tumble dryers with the rotation sensor.)
5. Hold the START button to display the drum RPM's; the display will read "h" where ## are the RPM's. (Only available on tumble dryers with the rotation sensor.)

Operating Instructions

Ignition Control Operation for Non-CE Models

Power Up

When power is applied to the ignition control, the control will begin the ignition sequence within 1 – 3 seconds prepurge waiting time.

Ignition Sequence

The control begins the ignition sequence after prepurge by powering the ignitor and opening the gas valve. The ignitor will remain on either until a flame is sensed or until a maximum of ten (10) seconds (10 +0/-4 sec) has elapsed. If a flame is established and lost during the 10 second period, the ignitor will be powered up again in an attempt to re-ignite the gas. If no flame is detected within the ten (10) second ignition sequence, the control will terminate power to the gas valves, ignitor, and enter lockout within 5 seconds.

Normal Operation

Once a flame has been established, the spark ignitor will stop sparking and the control will continually monitor all inputs. If the controller senses a loss of flame after flame is established, the gas valve will remain energized and sparking will commence within one second of the flame loss. If flame reattempt fails, lockout will occur within 11 seconds of initial flame loss.

Termination of Flame

Normal flame termination occurs when the thermostat has been satisfied, meaning there is no immediate need for more heat. The thermostat will disconnect power from the ignition control, which will cause the gas valve to close and the flame to go out. After a short period of time, not less than 1 second, the thermostat will cool down and close causing power to be reapplied to the ignition control. When this occurs, the control must complete the same prepurge and ignition sequence specified above.

Control Lockout

When the control locks out, the gas valve will be closed and all requests for heat will be ignored. The lockout mode may only be discontinued by interrupting power to the control or cycling the thermostat. After this occurs, the control will restart with its normal power up and ignition sequence.

Low Voltage Detection

Low Voltage Detection. The control will have capability for detection of a low voltage input condition. If input voltage on power up is below 19.0VAC +0.8VAC/-0.5VAC, the control will disable output to gas valve control relay. If input voltage rises above 19.8VAC for at least three (3) seconds, the control will then re-enable function of the gas valve control relay and ignition sequence may begin. On powerup, the control function must always be disabled if greater than 19.8VAC.

Ignition Control Operation for CE Models

Power Up

After 24 VAC is applied to the ignition control pins 24V and GND, the Diagnostic LED on the ignition control will turn orange/yellow. If a fault is detected the ignition control will enter Lockout Mode. If no faults are detected, the Diagnostic LED will turn Green and the ignition control will enter Standby Mode.

Standby Mode

While in Standby Mode, the ignition control will continually monitor the system for faults. Once 24VAC is applied to terminals TH and GND on the control, the ignition control will enter Start Up Mode.

Start Up Mode

During Start Up Mode, the ignition control will monitor the system for faults and begin the ignition sequence. If no faults are present, the ignition control will begin the ignition sequence by entering an 18 second waiting period. During this time the Green LED on the ignition control will switch between Red and Green, before maintaining a Green color.

After the waiting period, the ignition control will turn on the igniter and gas valve. The igniter will remain on until a flame is sensed, or up to 10 seconds.

Once a flame has been sensed the ignition control will stop sparking, the gas valve will remain on and ignition control will enter Run Mode.

If a flame is not sensed, the ignition control will then begin two additional retrials for ignition. The ignition control will re-enter the 18 seconds waiting period before the ignition control makes another attempt at ignition. If the three attempts at ignition fail, the ignition control will enter Lockout Mode.

Run Mode

While in Run Mode the ignition control leaves the gas valve on, monitors the flame signal, and leaves the igniter off.

If a flame signal is lost during Run Mode, one additional retrial for ignition will take place within one second. The ignition control will restore the spark for approximately 10 seconds. If the ignition re-attempt fails, the ignition control will enter Lockout Mode.

The ignition control will remain in Run Mode until 24VAC is removed from terminals TH and GND on the control.

Termination of Flame

The flame will go out when power is removed from ignition control. The ignition control will turn off the gas valve and enter Standby Mode.

Lockout Mode

When Lockout Mode is entered, the ignition control will remove power to the gas valve, the igniter will turn off, the Lockout/Reset Light will turn on, and the Diagnostic LED will display the appropriate Error Code.

Lockout Manual Reset

Lockout Mode is cleared by pressing an external reset switch for three seconds. The ignition control will clear all error codes and enter Standby Mode. During Lockout Manual Reset, the Diagnostic LED on the ignition control flashes red and orange, and the Reset Light remains on until the ignition control is reset. After the Reset Light turns off, stop pressing the switch. Holding the reset for three seconds after lockout has been cleared will cause a fault and result in entering Lockout Mode again.

Operating Instructions

System Tests

The following system tests are performed during normal operation. System tests are performed at a minimum of every 24 hours.

Low Voltage Detection

If the voltage between terminals TH and GND on the control is below 18.75VAC +/- 0.75VAC for more than 3 seconds the ignition control will turn off the gas valve and will not attempt to spark. The Diagnostic LED will display Error Code 5. The ignition control will not enter Lockout Mode if a low voltage condition is detected, but will enter Standby Mode and wait for the low voltage condition to be cleared.

If the voltage between terminals TH and GND on the control rises above 19.75VAC +/- 0.1VAC for at least 3 seconds, the ignition control will then enter Start Up Mode.

Low Voltage Detection test is disabled during Run Mode.

Gas Valve

The ignition control verifies that the gas valve is connected. Failure of this test results in the ignition control entering Lockout Mode with the Diagnostic LED displaying Error Code 2.

Flame Probe Tests

Unexpected Presence of Flame

The Unexpected Presence of Flame test is performed when no flame is expected. Failure of this test results in the ignition control entering Lockout Mode with the Diagnostic LED displaying Error Code 3.

Flame Monitoring

During the Flame Monitoring test, the flame is checked to ensure the gas is being burned when the gas valve is on. Failure of this test will result in the ignition control entering Lockout Mode with the Diagnostic LED displaying Error Code 3.

Diagnostic LED (DGN LED) / Error Codes

The Diagnostic LED or DGN LED is located by the power connector on the ignition control. Refer to *Figure 11*. The Diagnostic LED will indicate the status of the ignition control. Refer to *Table 5*.

LED Color	Description
Orange-Yellow	Initialization
Green	Standby / Normal Operation
Red	Fault Indication Code

Table 5

The Diagnostic LED will flash error codes one half second on and one half second off. Error codes are separated by a one second pause before the code is repeated.

Error Code	DGN LED status	Fault Type
1	Red	Ignition Control Internal Failure
2	2 Red Flashes	Gas Valve Not Connected
3	3 Red Flashes	Ignition/Flame Sense Failure
4	4 Red Flashes	Reset Switch is Shorted
5	Slow Red and Green Flashes	Low Voltage Detection
6	Fast Red and Orange Flashes	Ignition Control is in Reset Delay

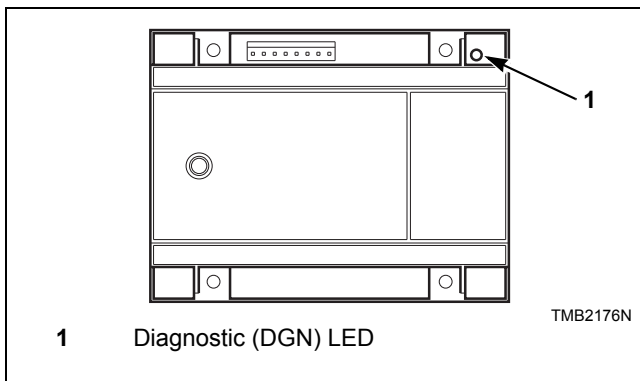

Figure 11

Maintenance



WARNING

To reduce the risk of electric shock, fire, explosion, serious injury or death:

- Disconnect electric power to the tumble dryer before servicing.
- Close gas shut-off valve to gas tumble dryer before servicing.
- Close steam valve to steam tumble dryer before servicing.
- Never start the tumble dryer with any guards/panels removed.
- Whenever ground wires are removed during servicing, these ground wires must be reconnected to ensure that the tumble dryer is properly grounded.

W002R1

Daily

1. Inspect the area surrounding tumble dryers, remove all combustible materials, including lint, before operating the machines.
 2. Check cylinder for foreign objects to avoid damage to clothing and equipment.
 3. Clean lint from lint compartment and screen to maintain proper airflow and avoid overheating.
- a. Open the lint panel.
 - b. Remove all accumulated lint in the lint compartment area. Lightly brush any lint that may be left on the lint screen. Lint left in the lint compartment is drawn back onto the lint screen and will restrict airflow.
 - c. Be sure the lint screen is not torn. If it is, replace immediately. A torn lint screen allows lint to pass from the tumble dryer to the ductwork system and may restrict airflow.
 - d. The lint screen is designed to completely cover the entire opening in the lint screen panel. Be sure that it does so. Excessive gaps between the lint screen and the lint screen panel allow lint to pass into the ductwork system and may restrict airflow.
 - e. Carefully wipe any accumulated lint off of the cabinet high limit thermostat and thermistor. Failure to do so will allow a buildup of lint in this area to act as an insulator, causing the tumble dryer to overheat. Refer to *Figure 12*.
 - f. Replace the lint panel on the tumble dryer ensuring a tight fit, and lock if applicable.



WARNING

To reduce the risk of serious injury, do not open the lint panel while the tumble dryer is in operation. Before cleaning the lint screen, open tumble dryer door and allow cylinder to completely stop.

W410R1



WARNING

To reduce the risk of electric shock, fire, explosion, serious injury or death:

- Disconnect electric power to the tumble dryer before servicing.
- Close gas shut-off valve to gas tumble dryer before servicing.
- Close steam valve to steam tumble dryer before servicing.
- Never start the tumble dryer with any guards/panels removed.
- Whenever ground wires are removed during servicing, these ground wires must be reconnected to ensure that the tumble dryer is properly grounded.

W002R1

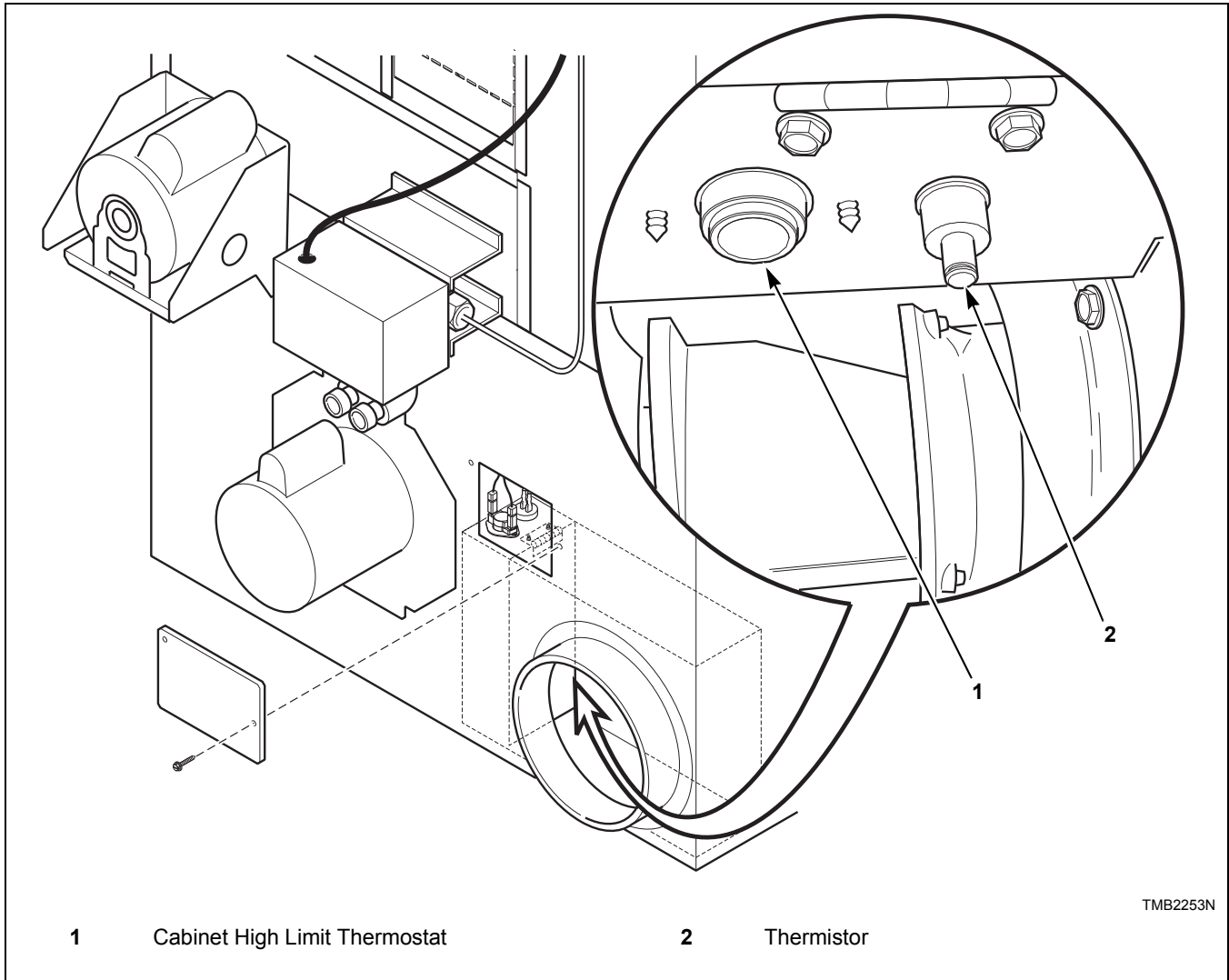

Figure 12



WARNING

To reduce the risk of electric shock, fire, explosion, serious injury or death:

- Disconnect electric power to the tumble dryer before servicing.
- Close gas shut-off valve to gas tumble dryer before servicing.
- Close steam valve to steam tumble dryer before servicing.
- Never start the tumble dryer with any guards/panels removed.
- Whenever ground wires are removed during servicing, these ground wires must be reconnected to ensure that the tumble dryer is properly grounded.

W002R1

Monthly

1. Remove lint and debris from inside exhaust duct to maintain proper airflow and avoid overheating.
 - a. Remove external duct and duct access covers, if present.
 - b. Clean inside of duct with a vacuum.
 - c. Clean dampers and make sure they operate freely.
 - d. Replace duct and all access covers before returning tumble dryer to operation.
2. Ensure even lint distribution over lint screen, replace if distribution of lint is uneven to maintain proper airflow and avoid overheating.
3. Carefully wipe any accumulated lint off the cabinet high limit thermostat and thermistor, including perforated cover. Lint buildup will act as an insulator, causing machine to overheat.
4. Clean lint and debris buildup from blower to maintain proper airflow, to avoid overheating and prevent possible vibration.

Quarterly

1. Use a vacuum to clean air vents on drive motors.
2. Use a vacuum to clean lint from rear limit thermostat cover.
3. Check and clean steam coils, if applicable.
4. Check flow of combustion and ventilation air.
5. Check belt tension and condition. Replace worn or cracked belts.

Bi-Annually

1. Check mounting hardware for any loose nuts, bolts or screws.
2. Check gas connections for leakage.
3. Check for loose electrical connections.
4. Check steam connections for looseness and leakage.
5. Remove all front panels and vacuum, including coin drop mechanisms.
6. Check cylinder and front panel seals.
7. Inspect cabinet and inner panels for any damage, replace or repair as needed.
8. Clean burner tubes and orifice area of any lint buildup.

Annually

1. Remove cylinder. Use a vacuum to clean lint from area around rear seal and idler assembly. Check seal idler assembly for wear.
2. Remove burner tubes and clean using water and a brush.

Maintenance

	WARNING
<p>To reduce the risk of electric shock, fire, explosion, serious injury or death:</p> <ul style="list-style-type: none"> • Disconnect electric power to the tumble dryer before servicing. • Close gas shut-off valve to gas tumble dryer before servicing. • Close steam valve to steam tumble dryer before servicing. • Never start the tumble dryer with any guards/panels removed. • Whenever ground wires are removed during servicing, these ground wires must be reconnected to ensure that the tumble dryer is properly grounded. 	
W002R1	

Daily Maintenance

Inspect the area surrounding tumble dryers, remove all combustible materials, including lint, before operating the machine.								
Check cylinder for foreign objects to avoid damage to clothing and equipment.								
Clean lint from lint compartment and screen to maintain proper airflow and avoid overheating.								

Monthly Maintenance

Remove lint and debris from inside exhaust duct to maintain proper airflow and avoid overheating.								
Ensure even lint distribution over lint screen, replace if distribution of lint is uneven to maintain proper airflow and avoid overheating.								
Carefully wipe any accumulated lint off the cabinet high limit thermostat and thermistor, including perforated cover. Lint buildup will act as an insulator, causing machine to overheat.								
Clean lint and debris buildup from blower to maintain proper airflow, to avoid overheating and prevent possible vibration.								



WARNING

To reduce the risk of electric shock, fire, explosion, serious injury or death:

- **Disconnect electric power to the tumble dryer before servicing.**
- **Close gas shut-off valve to gas tumble dryer before servicing.**
- **Close steam valve to steam tumble dryer before servicing.**
- **Never start the tumble dryer with any guards/panels removed.**
- **Whenever ground wires are removed during servicing, these ground wires must be reconnected to ensure that the tumble dryer is properly grounded.**

W002R1

Quarterly Maintenance

Use a vacuum to clean air vents on drive motors.								
Use a vacuum to clean lint from rear limit thermostat cover.								
Check and clean steam coils, if applicable.								
Check flow of combustion and ventilation air.								
Check belt tension and condition. Replace worn or cracked belts.								

Bi-Annually Maintenance

Check mounting hardware for any loose nuts, bolts or screws.								
Check gas connections for leakage.								
Check for loose electrical connections.								
Check steam connections for looseness and leakage.								
Remove all front panels and vacuum, including coin drop mechanisms.								
Check cylinder and front panel seals.								
Inspect cabinet and inner panels for any damage, replace or repair as needed.								
Clean burner tubes and orifice area of any lint buildup.								

Maintenance

Annual Maintenance

Remove cylinder. Use a vacuum to clean lint from area around rear seal and idler assembly. Check seal idler assembly for wear.								
Remove burner tubes and clean using water and a brush.								

Before You Call for Service

Won't Start	Won't Heat	Clothes Not Dry	Possible Reason – Corrective Actions
•			Insert correct coin(s) or valid card if applicable.
•			Close the loading door tightly.
•			Close lint panel tightly.
•			Press the START pad/button.
•			Be sure power cord is plugged all the way into the electrical outlet.
•			Check the main fuse and circuit breaker.
•			Check fuses located in the machine.
	•		Insufficient airflow.
	•		Gas shut-off valve in OFF position.
	•		Are controls properly set?
	•		Broken drive belt. Call the service person.
	•	•	Tumble Dryer is in Cool Down Mode.
	•	•	Lint screen clogged. Clean lint screen.
	•	•	Exhaust duct to outside is blocked. Clean out.

Customer Service

If literature or replacement parts are required, contact the source from which the machine was purchased or contact Alliance Laundry Systems at (920) 748-3950 for the name and address of the nearest authorized parts distributor.

For technical assistance, call (920) 748-3121.

