

# Washer-Extractor

Refer to Page 4 for Model Numbers

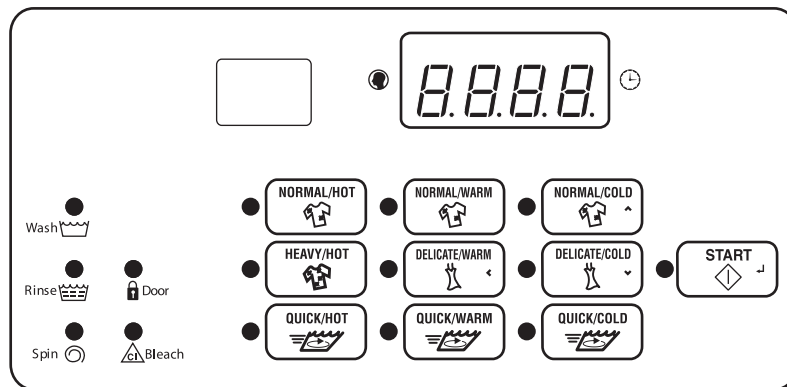

CHM1774C

## Keep These Instructions for Future Reference.

(If this machine changes ownership, this manual must accompany machine.)







## WARNING

Failure to install, maintain, and/or operate this machine according to the manufacturer's instructions may result in conditions which can produce bodily injury and/or property damage.

W030

**NOTE: The WARNING and IMPORTANT instructions appearing in this manual are not meant to cover all possible conditions and situations that may occur. It must be understood that common sense, caution, and carefulness are factors which cannot be built into these washer-extractors. These factors MUST BE supplied by the person(s) installing, maintaining, or operating the washer-extractor.**

Always contact the distributor, service agent, or the manufacturer about any problems or conditions you do not understand.

# Table of Contents

<b>Model Identification</b> .....	4
<b>Preliminary Information</b> .....	5
About the Control .....	5
Glossary of Terms.....	5
Power Failure Recovery .....	5
Communications .....	5
Infra-red Communication .....	5
<b>Control Identification</b> .....	6
Select Cycle Pads.....	6
<b>Display Identification</b> .....	7
Light Emitting Diodes (LEDs) .....	7
<b>Washer-Extractor Operation</b> .....	8
Start Up .....	8
Ready Mode.....	8
Partial Vend Mode.....	8
Additional Vend Mode .....	8
Start Mode .....	8
Door Locking Mode .....	8
Run Mode .....	8
End of Cycle Mode.....	8
Cycle Sequence.....	8
Door Unlocking Mode.....	8
Signals.....	9
Changing Cycles.....	9
<b>Special Features</b> .....	10
Programming Control .....	10
Collecting Audit Information .....	10
Rapid Advance Feature.....	10
Clearing the Vend Feature .....	10
Communications Mode.....	10
Coin Drop .....	10
Start Pulse Operation .....	10
Top Cover and Coin Vault Openings .....	10
Special Vend.....	10
OPL Mode .....	10
<b>Opening the Top Cover</b> .....	11
<b>Entering the Manual Mode</b> .....	12
How to Enter the Manual Mode .....	12
<b>Programming Control</b> .....	13
What Can Be Programmed? .....	13
Programmable Options Available.....	13
<b>Programming Flowcharts</b> .....	18
Entering Manual Mode .....	18
Manual Programming .....	19
Diagnostic .....	24
1. Normal/Hot Vend Price “AtS1” .....	25
2. Coin #1 Value “dEn1” .....	26
3. Coin #2 Value “dEn2” .....	27
4. Start Pulse Value “PLSE” .....	28
5. Start Pulse Mode “PLSn” .....	29
6. Available Type “AtyP” .....	30
7. Default Cycle “dCYC” .....	31

© Copyright 2010, Alliance Laundry Systems LLC

All rights reserved. No part of the contents of this book may be reproduced or transmitted in any form or by any means without the expressed written consent of the publisher.

8. OPL Mode Enable/Disable“oPL”	32
9. Audio Signal “AUd”	33
10. Card Reader Display Control “CArd”	35
11. Error Code Programming “Err-”	36
12. Cycle Programming “CyC-”	40
13. Supply/Compartment Dispenser Programming “SUPC”	45
14. Number of Balance Retries “bALr” (Variable Frequency Drives Only)	45
15. IR Access (On/Off) “IrA”	46
16. Fahrenheit/Celsius “t FC” (Models with Heat)	46
17. Hot Water Temperature “FH”	47
18. Warm Water Temperature “FHC”	47
19. Cold Water Temperature “FC”	48
20. Cooldown Enable/Temperature “Codn” (Models with Heat)	48
21. Production Test Cycle (On/Off) “PtEn”	49
22. Manual Rapid Advance (On/Off) “rAEn”	49
23. No Cycle Time Display “nCtd”	50
24. Programmable Cycle Time Display “PCtd”	50
25. Slow Drain Detection Adjust Value “SdAd”	51
26. Pause/Resume Mode (On/Off) “SPAU”	51
27. Normal/Warm Vend Price “AtS2”	52
28. Normal/Cold Vend Price “AtS3”	53
29. Heavy/Hot Vend Price “AtS4”	54
30. Delicate/Warm Vend Price “AtS5”	55
31. Delicate/Cold Vend Price “AtS6”	56
32. Quick/Hot Vend Price “AtS7”	57
33. Quick/Warm Vend Price “AtS8”	58
34. Quick/Cold Vend Price “AtS9”	59
35. Set Real-Time Clock “rtC-”	60
36. Special Vend A Data “SPA-”	61
37. Low Water Level “FLo”	80
38. Medium Water Level “FnEd”	80
39. High Water Level “FHI”	81
40. Auto-Water Leak Detection “ALd-”	81
<b>Collecting Audit Information</b>	83
<b>Manual Reset</b>	84
<b>Production Test Cycle</b>	85
<b>Error Codes</b>	88
<b>Rapid Advance Feature</b>	91
<b>Clear Vend Feature</b>	92
<b>Power Fail Recovery</b>	93
<b>Communications Mode</b>	94
Infra-red Communications	94
Card Reader Communications (Card Models Only)	94
<b>Default Cycles</b>	95

# Model Identification

Information in this manual is applicable to these washer-extractor models:

<b>20</b>	SCN020JC2 SCN020JCF	SCN020JCV SCN020JY2	SCN020JYF SCN020JYV		
<b>30</b>	SCN030JC2 SCN030JCF	SCN030JCV SCN030JE2	SCN030JEF SCN030JX2	SCN030JY2 SCN030JYF	SCN030JYV
<b>40</b>	SCN040JC2 SCN040JCF	SCN040JCV SCN040JD2	SCN040JE2 SCN040JEF	SCN040JY2 SCN040JYF	SCN040JYV
<b>60</b>	SCN060JC2 SCN060JCF	SCN060JCV SCN060JD2	SCN060JDF SCN060JX2	SCN060JY2 SCN060JYF	SCN060JYV
<b>80</b>	SCN080JCF SCN080JCV	SCN080JYF SCN080JYV			

# Preliminary Information

## About the Control

This control is an advanced, programmable computer that lets the owner control most machine features by pressing a sequence of keypads. Refer to *Figure 1*.

The control allows the owner to program custom cycles, set vend prices, retrieve audit information, program special vend features and other programmable features. Refer to ***Programming Control*** for a list of features. Washer-extractors shipped from the factory have a default cycle and wash temperature setting of DELICATE/WARM built in. However, the owner can change the default cycle, or any cycle, as needs permit.

**IMPORTANT: In the event of a power failure, the control will not have to be reprogrammed. It is designed with a memory system that will remember how it was programmed until the electrical power is restored.**

**IMPORTANT: It is extremely important that the washer-extractor has a good ground connection and that all mechanical and electrical connections to the control are made before applying power to or operating the washer-extractor.**

## Glossary of Terms

The following are a few terms and abbreviations to learn. These are referred to throughout the instructions.

Display – This term refers to the window area of the control that displays words and values.

LED (Light Emitting Diode) - This term refers to the lights next to the keypads and status words of the control.

## Power Failure Recovery

If a cycle is in progress and the power fails, the cycle status is saved in memory. When the power recovers, the washer-extractor will resume into the previously active cycle automatically without user input if the length of the power failure was less than two minutes.

If the length of the power failure is greater than two minutes, the control will return to Start Mode and the cycle step where the power failure occurred. User must press START pad to resume the cycle.

## Communications

The control may be programmed manually or by infra-red communication with an external device. A limited number of features can be programmed by a card reader.

### Infra-red Communication

An external device, such as a PDA, allows the owner to program and retrieve information from the control without touching the keypad. An external device greatly expands the programming options available to the owner. However, it is not required to program and operate the washer-extractor. The operation of an external device and the advanced features available are covered separately in the instructions included with the external device software. Contact Alliance Laundry Systems for a list of approved PDAs and other external devices.

### Serial Card Reader Communications (Card Models Only)

The control will accept communication with a serial card reader in order to perform vending transactions when a card is inserted to pay for cycles. The card reader can also allow the owner to program a limited number of features and collect audit information.

For detailed information on the serial card reader communications, refer to instructions included with the card reader.

# Control Identification

## Select Cycle Pads

Refer to *Figure 1*.

Select Cycle pads are used to select the specific washer cycle. These pads include NORMAL/HOT, NORMAL/WARM, NORMAL/COLD, HEAVY/HOT, DELICATE/WARM, DELICATE/COLD, QUICK/HOT, QUICK/WARM and QUICK/COLD. These pads allow the user to select a cycle other than

the default cycle (DELICATE/WARM). The Select Cycle keypads are not active after the first fill step of the cycle. The selected cycle is indicated by the light (LED) on the pad. Pressing the flashing START pad will confirm the selection and the cycle will begin. When the card reader is used, pressing the START pad will start the cycle and deduct the vend price from the card.

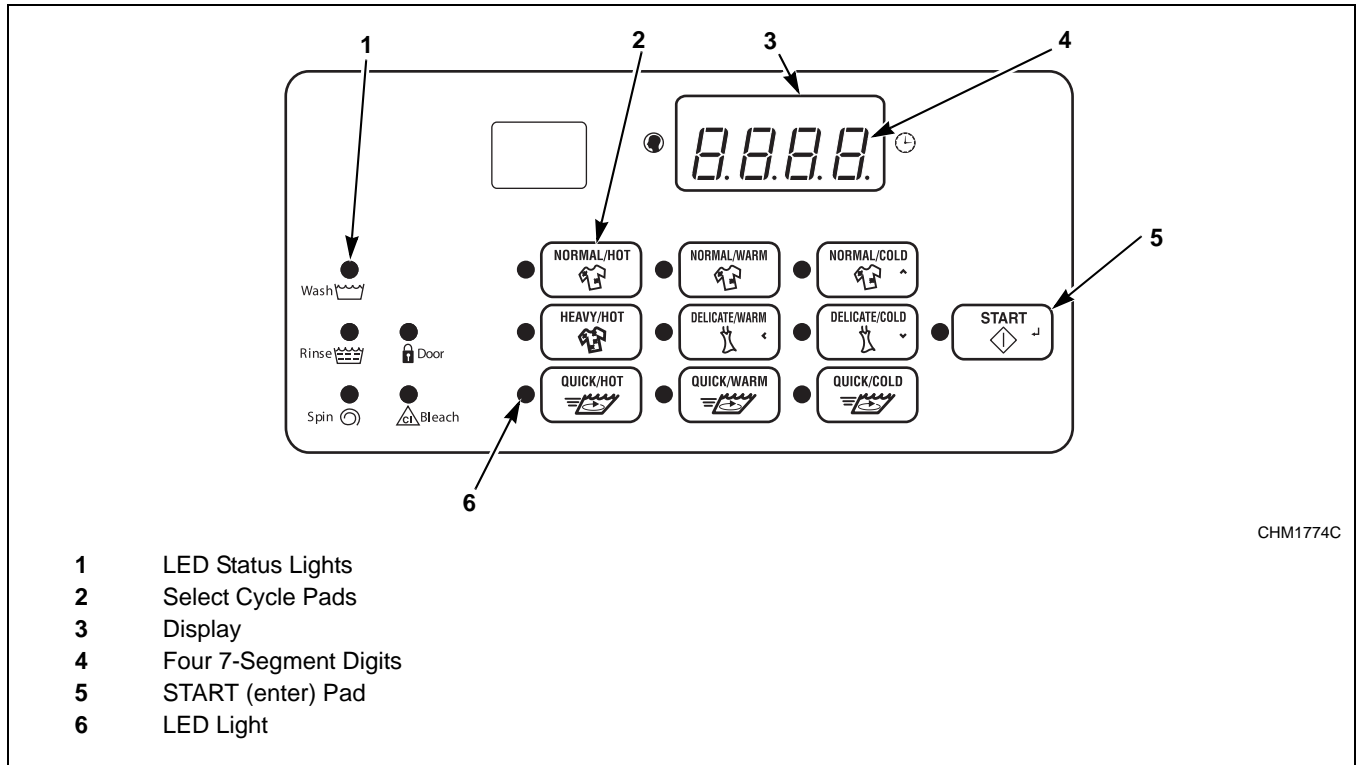

Figure 1

# Display Identification

## Light Emitting Diodes (LEDs)

Refer to *Figure 1*.

Light Emitting Diodes (LEDs) are used to indicate the chosen cycle, cycle status, if vend is needed, when the bleach compartment is dispensing, and door lock information. See below for information on each LED.

### **Cycle LED (NORMAL/HOT, NORMAL/WARM, NORMAL/COLD, HEAVY/HOT, DELICATE/WARM, DELICATE/COLD, QUICK/HOT, QUICK/WARM and QUICK/COLD)**

*Cycle* LED will remain lit the entire cycle.

### **Wash LED**

*Wash* LED is lit at the beginning of a wash portion of the cycle and will remain lit until the wash is complete.

### **Rinse LED**

*Rinse* LED is lit at the beginning of a rinse portion of the cycle and will remain lit until the rinse is complete.

### **Spin LED**

*Spin* LED is lit during the Final Spin portion of the cycle.

### **Door LED**

*Door* LED is lit whenever the door is locked. The door can't be opened when this LED is lit.

### **Bleach LED**

*Bleach* LED is lit when bleach compartment is dispensing for the first time in the cycle.

### **Four 7-Segment Digits**

The 7-Segment Digits are used to display the time remaining in a cycle, vend price, error messages and descriptive codes. During Diagnostic Testing or Manual Programming of the control, these digits will display descriptive codes and values (as described in *Entering the Manual Mode*).

# Washer-Extractor Operation

## Start Up

When power is applied to the washer-extractor, the control will display its software version as “S xx” (“xx” is the version number) for one (1) second. If the control was not powered down during a running cycle, it will enter Ready Mode, Partial Vend Mode or Start Mode.

## Ready Mode

In this mode of operation the control indicates the current selected cycle by lighting the LEDs. The full current vend price for the cycle appears in the display.

To start the cycle, the user must satisfy the vend price and then press the START keypad.

The user will be able to select a different cycle by pressing a cycle pad when the machine is in Ready Mode.

## Partial Vend Mode

The control enters this mode when part of the vend price has been entered, but not enough vend is entered to satisfy the vend price. The control will display the remaining vend price needed to start the cycle.

The user will be able to select a different cycle by pressing a cycle pad when the machine is in Partial Vend Mode.

## Additional Vend Mode

The control enters this mode if a higher priced cycle is selected while the machine is in Start Mode or Run Mode, but before the first fill has completed. If the vend price is not satisfied within 1 minute, the control will go back to the first selection and the cycle will continue if it was paused. After the first fill, all key presses will be ignored, allowing the washer to go through the complete cycle.

## Start Mode

The control enters this mode when the full vend price is satisfied, the vend price is zero, the control is in OPL Mode. The START pad LED will flash one (1) second on and one (1) second off. If Start Mode is entered because the vend price is satisfied or the control is in OPL Mode, the display will show “PUSH” for one (1) second, “Strt” for one (1) second and the current cycle time for one (1) second. If Start Mode is entered because the vend price is zero, the display will show “FREE”. When first entering Start Mode, a signal will sound for one (1) second on and one (1) second off for 10 seconds if Signal for Start is enabled.

After pressing the START keypad, the door will lock and the cycle will begin.

## Door Locking Mode

The control enters this mode after the START (enter) keypad is pressed in Start Mode. The control stays in Door Locking Mode until it confirms the door is closed and locked.

## Run Mode

The control enters this mode when a cycle is running. The time remaining appears in the display, the status LEDs are lit and the loading door is locked.

## End of Cycle Mode

When a cycle is complete, the control will display “00” until the washer door is opened, a key is pressed, or a coin/card is entered. The display will revert back to Ready Mode if door is opened or keypad is pressed. If vend is entered, the control will change to Partial Vend Mode or Start Mode.

## Cycle Sequence

Upon the start of a cycle, the control will display the total cycle time. The appropriate LEDs will light while the machine passes through different cycle steps. Any coin entered after the first fill cycle has been started will be added to the total coin counter, but the user will not be able to change cycles or water temperature.

## Door Unlocking Mode

The control enters this mode after cycle has ended. The control waits for confirmation that door is unlocked. Once confirmation is received that door is unlocked, control will enter End of Cycle Mode.

## Signals

There are five options when a signal can be used during the washer operation. These five options are listed below:

1. **End of Cycle Signal**  
By default, this signal is turned off. If turned on, the signal sounds for three (3) seconds at the end of a cycle.
2. **Signal On Keypad Depression**  
By default, this signal is turned on and sounds for a quarter of a second each time a keypad is pressed.
3. **Signal On Coin Input/Card Insertion**  
By default, this signal is turned on and will sound for a quarter of a second each time a coin or card is entered.
4. **Signal for Card Removal (Card Models Only)**  
By default, this signal is turned on and will sound one (1) second on and one (1) second off when the control is prompting for card removal.
5. **Signal for Start**  
By default, this signal is turned on and will sound one (1) second on and one (1) second off for 10 seconds after vend price has been satisfied.

**NOTE: Refer to *Programming Control* to program signal options.**

## Changing Cycles

Cycles can be changed anytime during the first Fill step. After the first Fill step, all key presses are ignored.

Selecting a higher priced cycle will pause the first Fill step, and the Vend Price will flash one (1) second on and one (1) second off until the vend price has been satisfied. After the vend price has been satisfied, the cycle will continue with the new selections. If the vend price is not satisfied within 1 minute, the washer control will go back to the previously set cycle.

# Special Features

## Programming Control

The control allows the washer-extractor owner to program the control with the use of the keypad. Cycle and vend options may be programmed, audit information may be viewed and diagnostic tests may be run by pressing combinations of the Select Cycle keypads.

For details on programming Select Cycle and vend options, refer to *Programming Control*.

## Collecting Audit Information

The control will store audit information in its memory that can be retrieved by pressing various combinations of Select Cycle keypads. The control will record coins entered, total machine cycles, total start pulses and total rapid advance cycles.

For more information on the audit features, refer to *Collecting Audit Information*.

**NOTE: Additional audit information is retrievable with an external device and the card reader. Refer to the appropriate instruction manual.**

## Rapid Advance Feature

This feature allows the user to quickly advance through active cycles or advance into a cycle from Ready Mode. This feature is useful when tests must be performed immediately on a washer-extractor currently in an active cycle. In this case, the user can quickly advance through the cycles to the shake out step, then End of Cycle Mode. At this point, the user can perform the required tests and then return the washer-extractor to the point it was interrupted.

For detailed information on using the Rapid Advance feature, refer to *Rapid Advance Feature*.

## Clearing the Vend Feature

This feature allows the user to return the control back to Ready Mode if coins have been entered but the full vend price has not yet been satisfied.

For more information on using the Clear Vend feature, refer to *Clear Vend Feature*.

## Communications Mode

This feature allows the control to communicate with an external device or the card reader. This allows the control to be programmed and have its data read without using the keypad.

For more detailed information on using the Communications Mode feature, refer to *Communications Mode*.

## Coin Drop

The control will accept pulses from a single or dual coin drop to satisfy vend price. Each coin drop will have the ability to start a cycle.

## Start Pulse Operation

The control will accept pulses from optional payment systems. The machine can be programmed to receive a single start pulse or multiple start pulses, or the Start Pulse Option can be turned off. The Start Pulse Mode allows the machine to go from Ready Mode to the Start Mode after a single pulse or multiple pulses are received.

## Top Cover and Coin Vault Openings

The control will capture the times and dates of the openings of the Coin Vault and the Top Cover. The information is saved in memory. An open top cover combined with various keypad presses allows the control to enter manual modes of operation. These modes include Manual Programming, Audit Collection and Diagnostics.

## Special Vend

This feature allows the owner to program the control to allow programmable vend prices for specific hours and dates.

For details on programming Special Vend, refer to *Programming Control*.

## OPL Mode

This feature allows the user to start a cycle without satisfying the vend price.

For details on enabling OPL Mode, refer to *Programming Control*.

# Opening the Top Cover

To manually program the control, the top cover must be opened. Opening and closing the top cover trips a switch which allows access to various programming options. Once opened, the top cover may either be left open, and then closed after programming, or it may be closed immediately.

The top cover is located on the top of the washer-extractor.

1. Unlock top cover.
2. Slide top cover forward slightly to move notches away from the pegs on the front of the cabinet.

3. Lift the top cover up. To completely remove, lift top cover away from both top cover hinges. Refer to *Figure 2*.

After opening, or opening and closing the top cover, the operator has 4 minutes and 15 seconds to begin programming. If the appropriate Select Cycle Pads have not been pressed in that time, the control will not accept operator programming. Should this happen, opening and closing the top cover will once again trip the switch which allows access to the programming options.

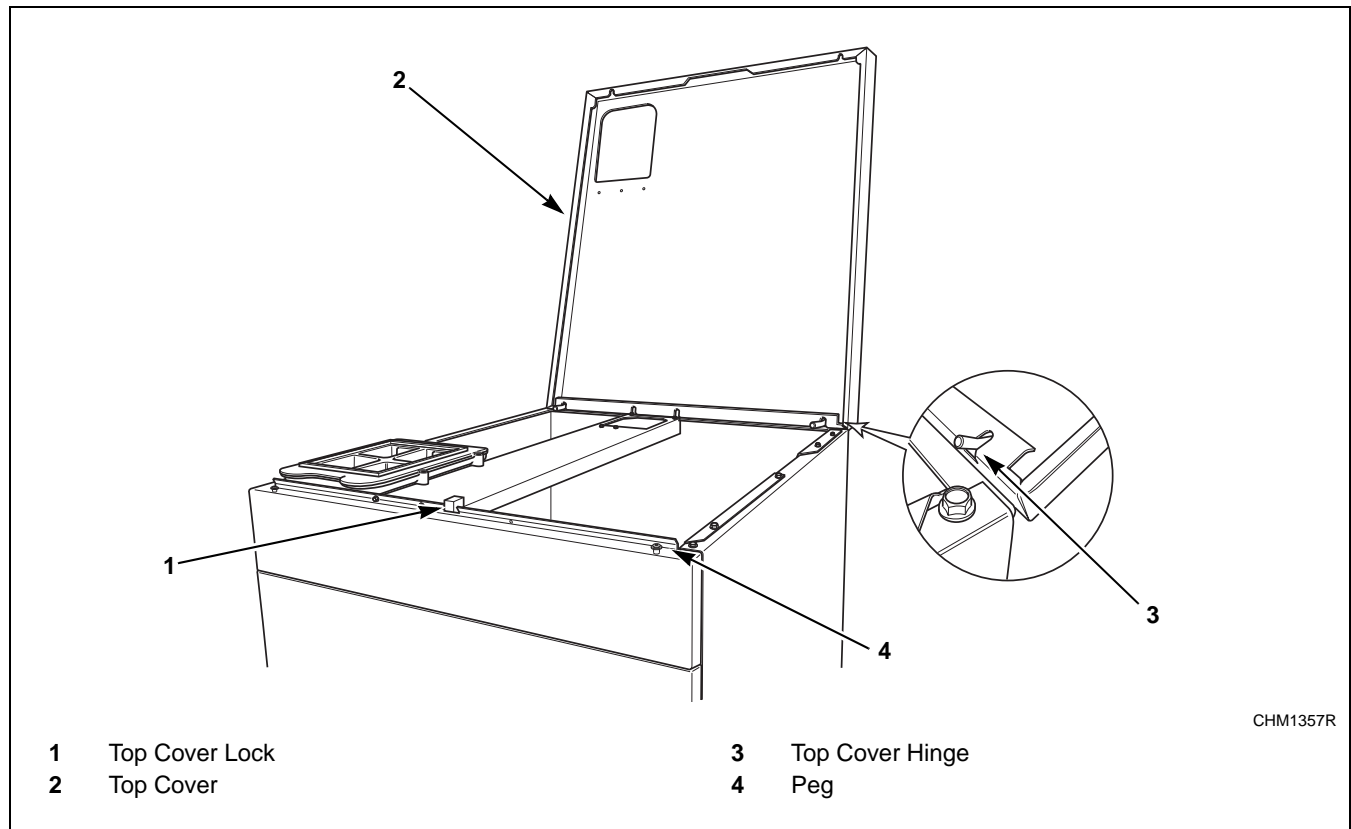

Figure 2

# Entering the Manual Mode

For programming, testing, and retrieving information from the control, it is often necessary to enter the Manual Mode by following the six simple steps below.

## How to Enter the Manual Mode

1. If accessing Diagnostic Tests, be sure the washer is in the Ready Mode before continuing to step 2. If the washer is in an active cycle, rapid advance through the cycle. Refer to the **Rapid Advance Feature**. If coins or a card has been entered, refer to **Clear Vend Feature**.
2. Open the top cover. Refer to **Opening the Top Cover**.

**NOTE: The coin vault switch must be closed to enter Manual Mode.**

3. While pressing and holding the HEAVY/HOT keypad with one hand, press the NORMAL/HOT keypad with the other hand.
4. The display will show “rAPd”.
5. Press the NORMAL/COLD (^) keypad or the DELICATE/COLD (v) keypad to scroll through the options until the desired option appears in the display.
6. Press the START (enter) keypad.

Manual Mode is broken into two groups: Manual Programming and Manual Rapid Advance. Manual Programming can only be turned on or off with an external device. Refer to the appropriate instruction manual. Manual Rapid Advance can be turned on and off using an external device or by manual programming (refer to *option 22 of Programming Control*).

By default, all groups are turned “ON”.

The manual features available in each group are as follows (the menu displayed on the display in this mode is in parentheses).

## Manual Programming

Manual Programming (Prog)

Manual Read Audit (AUdt)

Manual Reset (rSEt)

## Manual Rapid Advance

Rapid Advance (rAPd)

# Programming Control

## What Can Be Programmed?

This feature allows the owner to program cycle information, standard vend pricing, special vends and other features by using the keypads. The control must have the Manual Programming Mode enabled, which is the factory default. This mode can only be turned “OFF” and “ON” by using an external device. Refer to this section when programming the control.

This section offers a detailed description of all available programmable options.

Each description includes instructions on when and why the option might be used and, more importantly, how to program the option.

For more advanced users, a quick reference list of the options available through the programming mode and programming flowcharts are located on the following pages..

**NOTE: The letters and numbers in the Option Display column of the Programmable Options List are what will be shown in the display when that option is selected.**

## Programmable Options Available

Option Number	Option Display	Description	Default Value	Value Range
1	“AtS1”	Normal/Hot Vend Price	200	0 - 65535
2	“dEn1”	Coin #1 Value	25	1 - 65535
3	“dEn2”	Coin #2 Value	100	1 - 65535
4	“PLSE”	Start Pulse Value	25	1 - 65535
5	“PLSn”	Start Pulse Mode	128	oFF/128/192
6	“AtyP”	Available Type	0	0 - 3
7	“dCYC”	Default Cycle	5*	1 - 9*
8	“oPL”	OPL Mode Enable/Disable	oFF	on/oFF
9	“AUd”	Audio Signal	29*	0-31*
10	“CArd”	Card Reader Display Control	oFF	on/oFF
11	“Err-”	Errors	—	—
a.	“CEr-”	Coin Error Parameters	—	—
1.	“CEr1”	Coin Error	on	on/oFF
2.	“CEr2”	Coin Error Penalty	oFF	on/oFF
3.	“CEr3”	Coin Drops Header Present Error	on	on/oFF
b.	“E FL”	Fill Error	on	on/oFF
c.	“E dr”	Drain Error	on	on/oFF
d.	“E Ub”	Unbalance Error Display	on	on/oFF
e.	“E oP”	Open Thermistor Error Display	on	on/oFF
f.	“E SH”	Shorted Thermistor Error Display	on	on/oFF
g.	“E Ht”	Heat Error Display (Heater only)	on	on/oFF
h.	“LEr-”	Water Leak Detection Error	—	—
1.	“LEr1”	Water Leak Detection During a Machine Cycle (On/Off)	oFF	on/oFF

\*Refer to programming section for value definition.

\*\*Refer to the *Cycle Charts* for default cycle setting informaton.

Table 1 (continued)

Programming Control

Table 1 (continued)

Option Number	Option Display	Description	Default Value	Value Range
2.	“LEr2”	Water Leak Detection Day of Week Enable	127*	0 - 127*
3.	“LEr3”	Number of cycles between Leak Detection Test	0*	0 - 127
i.	“E Sd”	<b>Slow Drain Detection</b>	oFF	on/oFF
12	“CyC-”	<b>Cycle Programming</b>	Refer to Cycle Chart for default cycle information	
a.	“AgIt”	<b>Cycle Agitate</b>	—	—
1.	“tyPE”	<b>Agitate Type</b>	**	1 - 2*
2.	“ASPD”	<b>Agitate Speed (Vfd only)</b>	**	Lo/rEg*
b.	“SEg-”	<b>Cycle Segment Programming</b>	—	—
1.	“SgEn”	Segment Enable/Disable	**	on/oFF
c.	“FILL”	<b>Fill Step</b>	—	—
1.	“FLEn”	Fill step Enable/Disable	**	on/oFF
2.	“FLEU”	Fill Level	**	Hi/med/Lo
3.	“tEnP”	Fill Temperature	**	35°F - 194°F/ 2°C-90°C
d.	“SUPL”	<b>Supply Step</b>	—	—
1.	“SUEn”	Supply Step Enable/Disable	**	on/oFF
2.	“dISP”	Dispenser Options	**	Display will show Cx (compartment-oriented) or Sx (supply-oriented), depending on how option 5 (Supply/Compartment Dispenser Programming) is programmed
a.	“C2” or “S1”	Compartment #2/Supply #1	**	on/oFF
b.	“C3” or “S2”	Compartment #3/Supply #2	**	on/oFF
c.	“C4” or “S3”	Compartment #4/Supply #3	**	on/oFF
d.	“S4”	Supply #4	**	on/oFF
e.	“SdUr”	Supply Duration	**	Press START keypad to access options
1.	“SEC”	Seconds	**	0/59
2.	“nIn”	Minutes	**	0 - 9
f.	“AgSt”	<b>Agitate step</b>	—	—
1.	“AgEn”	Agitate Step Enable/Disable	**	on/oFF

\*Refer to programming section for value definition.

\*\*Refer to the Cycle Chart for default cycle setting informaton.

Table 1 (continued)

Table 1 (continued)

Option Number	Option Display	Description	Default Value	Value Range
2.	“AdUr”	<i>Agitate Duration (in minutes)</i>	**	1 - 30 for agitate types 1 or 2
3.	“HEAt”	<i>Heat in Agitate (if heater is present)</i>	**	oFF/1/2**
g.	“drAn”	<b>Drain Step</b>	on	on/oFF
h.	“SPIn”	<b>Extract Step</b>	—	—
1.	“SPEn”	<i>Extract Step enable/Disable</i>	**	on/oFF
2.	“SSEC”	<i>Extract Seconds</i>	**	0 - 59
3.	“SnIn”	<i>Extract Minutes</i>	**	<b>Intermediate Extract:</b> Min. Step Time = 30 seconds, Max. Step Time = 3:59 minutes <b>Final Extract:</b> Min. Step Time = 30 seconds, Max. Step Time = 9:59 minutes
4.	“SSPd”	<i>Extract Speed (VFD only)</i>	**	1 - 5*
i	“Cnin”	<b>Cycle Time</b>	0*	0 - 255 minutes
13	“SUPC”	<b>Supply/Compartment Dispenser Programming</b>	C (Compartment)	C (Compartment)/S (Supply Dispenser)
14	“bALr”	<b>Number of Balance Retries (VFD only)</b>	3	1 - 7
15	“IrA”	<b>IR Access (On/Off)</b>	on	on/oFF
16	“t FC”	<b>Fahrenheit/Celsius</b>	FAHr (Fahrenheit)	FAHr (Fahrenheit)/ CEL (Celsius)
17	“FH”	<b>Hot Water Temperature</b>	140°F (60°C)	35°F - 194°F/ 2°C - 90°C
18	“FHC”	<b>Warm Water Temperature</b>	100°F (38°C)	35°F - 194°F/ 2°C - 90°C
19	“FC”	<b>Cold Water Temperature</b>	35°F (2°C)	35°F - 194°F/ 2°C - 90°C
20	“Codn”	<b>Cooldown Enable/Temperature</b>	oFF	oFF or 50°F - 160°F/ 10°C - 71°C
21	“PtEn”	<b>Production Test Cycle (On/Off)</b>	on	on/oFF
22	“rAEn”	<b>Manual Rapid Advance (On/Off)</b>	on	on/oFF
23	“nCtd”	<b>No Cycle Time Display</b>	oFF	on/oFF
24	“PCtd”	<b>Programmable Cycle Time Display</b>	oFF	on/oFF
25	“SdAd”	<b>Slow Drain Detection Adjust</b>	0	0 - 255

\*Refer to programming section for value definition.

\*\*Refer to the *Cycle Charts* for default cycle setting informaton.

Table 1 (continued)

Programming Control

Table 1 (continued)

Option Number	Option Display	Description	Default Value	Value Range
26	“SPAU”	Pause/Resume Mode	oFF	on/oFF
27	“AtS2”	Normal/Warm Vend Price	200	0 - 65535
28	“AtS3”	Normal/Cold Vend Price	200	0 - 65535
29	“AtS4”	Heavy/Hot Vend Price	200	0 - 65535
30	“AtS5”	Delicate/Warm Vend Price	200	0 - 65535
31	“AtS6”	Delicate/Cold Vend Price	200	0 - 65535
32	“AtS7”	Quick/Hot Vend Price	200	0 - 65535
33	“AtS8”	Quick/Warm Vend Price	200	0 - 65535
34	“AtS9”	Quick/Cold Vend Price	200	0 - 65535
35	“rtC-”	Real Time Clock	—	—
a.	“rtC1”	Set Real Time Clock Minutes	—	00 - 59
b.	“rtC2”	Set Real Time Clock Hours	—	00 - 23
c.	“rtC3”	Set Real Time Clock Day	—	001 (Sunday) - 007 (Saturday)
d.	“rtC4”	Set Real Time Clock Date	—	1 - 31
e.	“rtC5”	Set Real Time Clock Month	—	1 - 12
f.	“rtC6”	Set Real Time Clock Year	—	0 (2000) - 99
g.	“rtC7”	Daylight Savings Option	on	on/oFF
36	“SPA-”	Special Vend A Data	—	—
a.	“SA01”	Special Vend A Days Enable	0*	0 - 255*
b.	“SA02”	Special Vend A Start Hour	—	0 - 23
c.	“SA03”	Special Vend A Start Minute	—	0 - 59
d.	“SA04”	Special Vend A Length in Hours	—	0 - 24
e.	“SA05”	Special Vend A Start Month	—	1 - 12
f.	“SA06”	Special Vend A Start Date	—	1 - 31
g.	“SA08”	Special Vend A End Month	—	1 - 12
h.	“SA09”	Special Vend A End Date	—	1 - 31
i.	“SA11”	Special Vend A Normal/Hot Vend Price	—	0 - 65535
j.	“SA12”	Special Vend A Normal/Warm Vend Price	—	0 - 65535
l.	“SA13”	Special Vend A Normal/Cold Vend Price	—	0 - 65535
m.	“SA14”	Special Vend A Heavy/Hot Vend Price	—	0 - 65535
n.	“SA15”	Special Vend A Delicate/Warm Vend Price	—	0 - 65535
o.	“SA16”	Special Vend A Delicate/Cold Vend Price	—	0 - 65535
q.	“SA17”	Special Vend A Quick/Hot Vend Price	—	0 - 65535
r.	“SA18”	Special Vend A Quick/Warm Vend Price	—	0 - 65535
s.	“SA19”	Special Vend A Quick/Cold Vend Price	—	0 - 65535

\*Refer to programming section for value definition.

\*\*Refer to the *Cycle Charts* for default cycle setting informaton.

Table 1 (continued)

Table 1 (continued)

Option Number	Option Display	Description	Default Value	Value Range
t.	“SA20”	Special Vend A Wash Agitate Step Added Minutes	—	0 - 15
u.	“SA21”	Special Vend A Wash Agitate Step Subtracted Minutes	—	0 - 15
<b>37</b>	<b>“FLo”</b>	<b>Low Water Level</b>	3	1 - 10
<b>38</b>	<b>“FnEd”</b>	<b>Medium Water Level</b>	15	11 - 20
<b>39</b>	<b>“FHI”</b>	<b>High Water Level</b>	27	21 - 30
<b>40</b>	<b>“ALd-”</b>	<b>Auto-Water leak Detection</b>	—	—
a.	“ALd1”	Auto-Water Leak Detection (On/Off and cycles)	oFF	oFF/0-127 (Cycles)
b.	“ALd2”	Auto-Water Leak Detection Hour	0	0 - 23
c.	“ALd3”	Auto-Water Leak Detection Day of Week	127*	0 - 127*

\*Refer to programming section for value definition.

\*\*Refer to the *Cycle Charts* for default cycle setting informaton.

Table 1

# Programming Flowcharts

## Entering Manual Mode

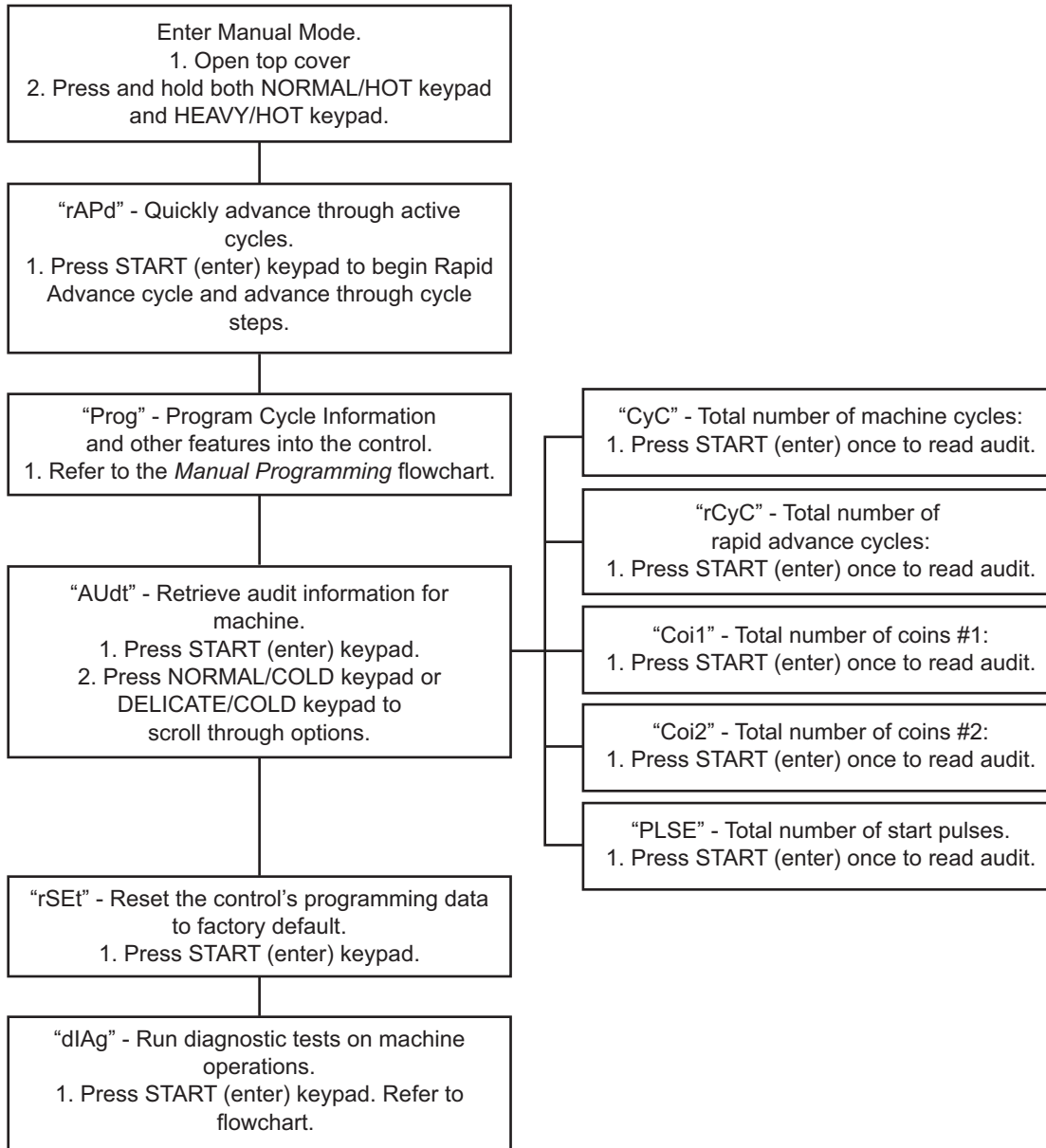

# Manual Programming

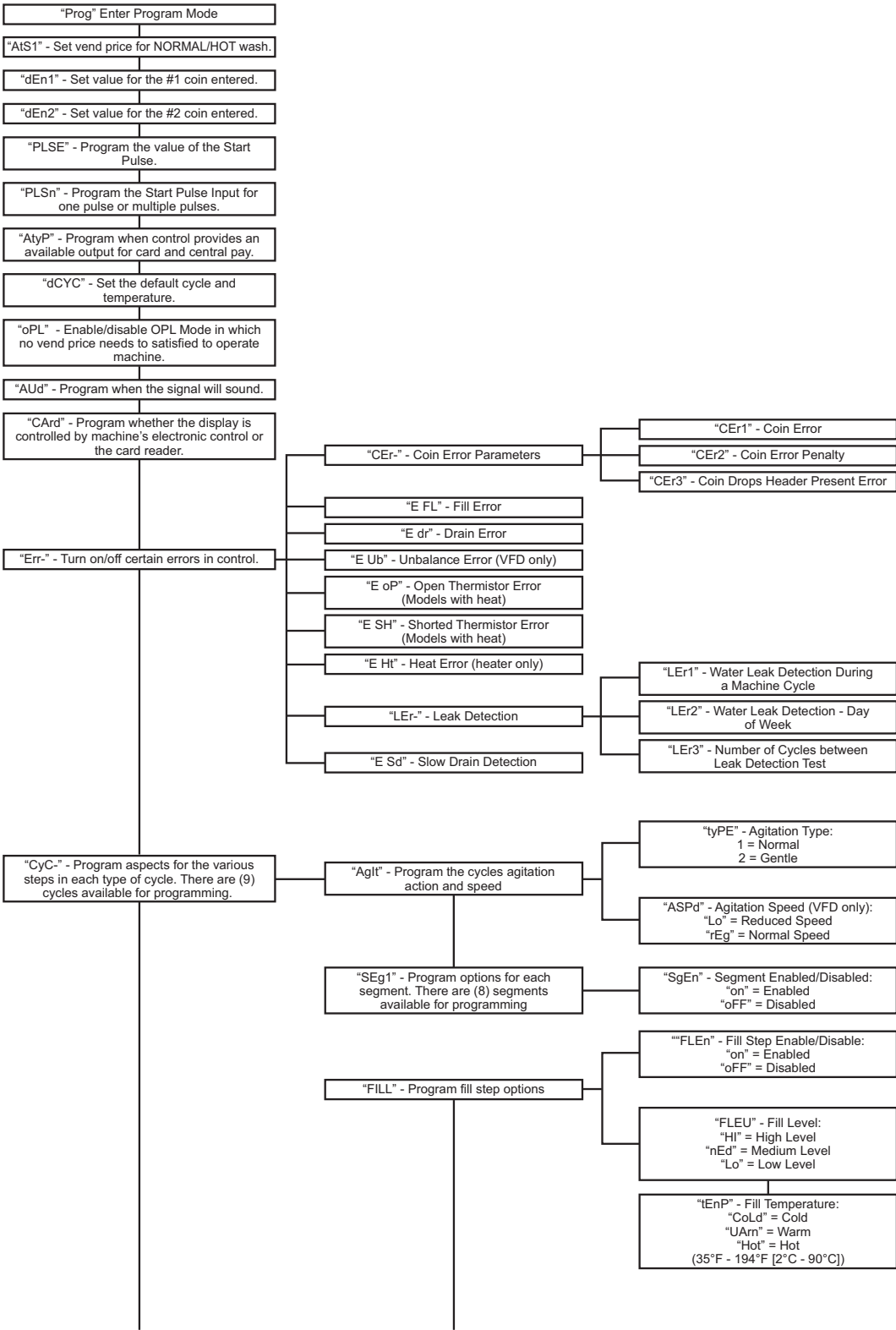

(continued)

(continued)

# Programming Flowcharts

(continued)

(continued)

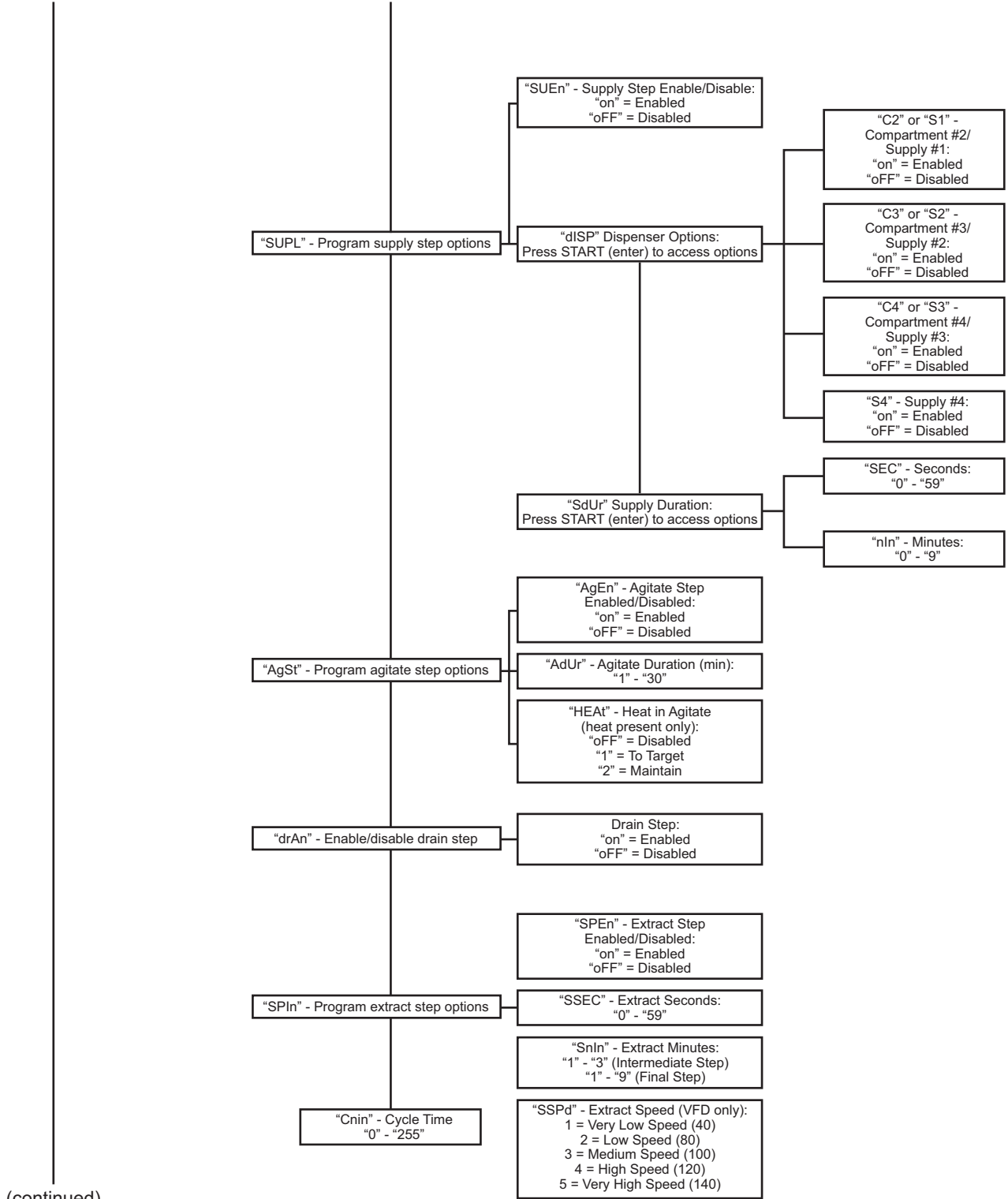

(continued)

(continued)

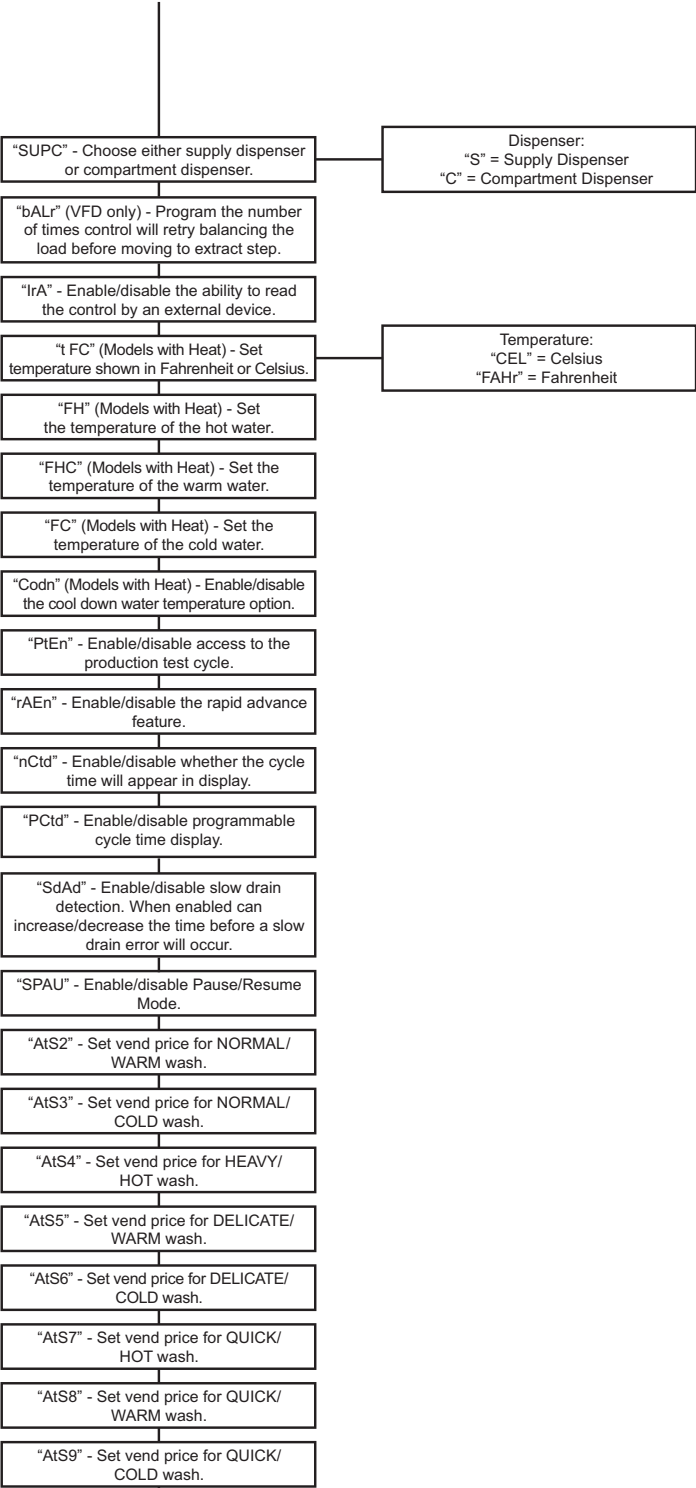

(continued)

# Programming Flowcharts

(continued)

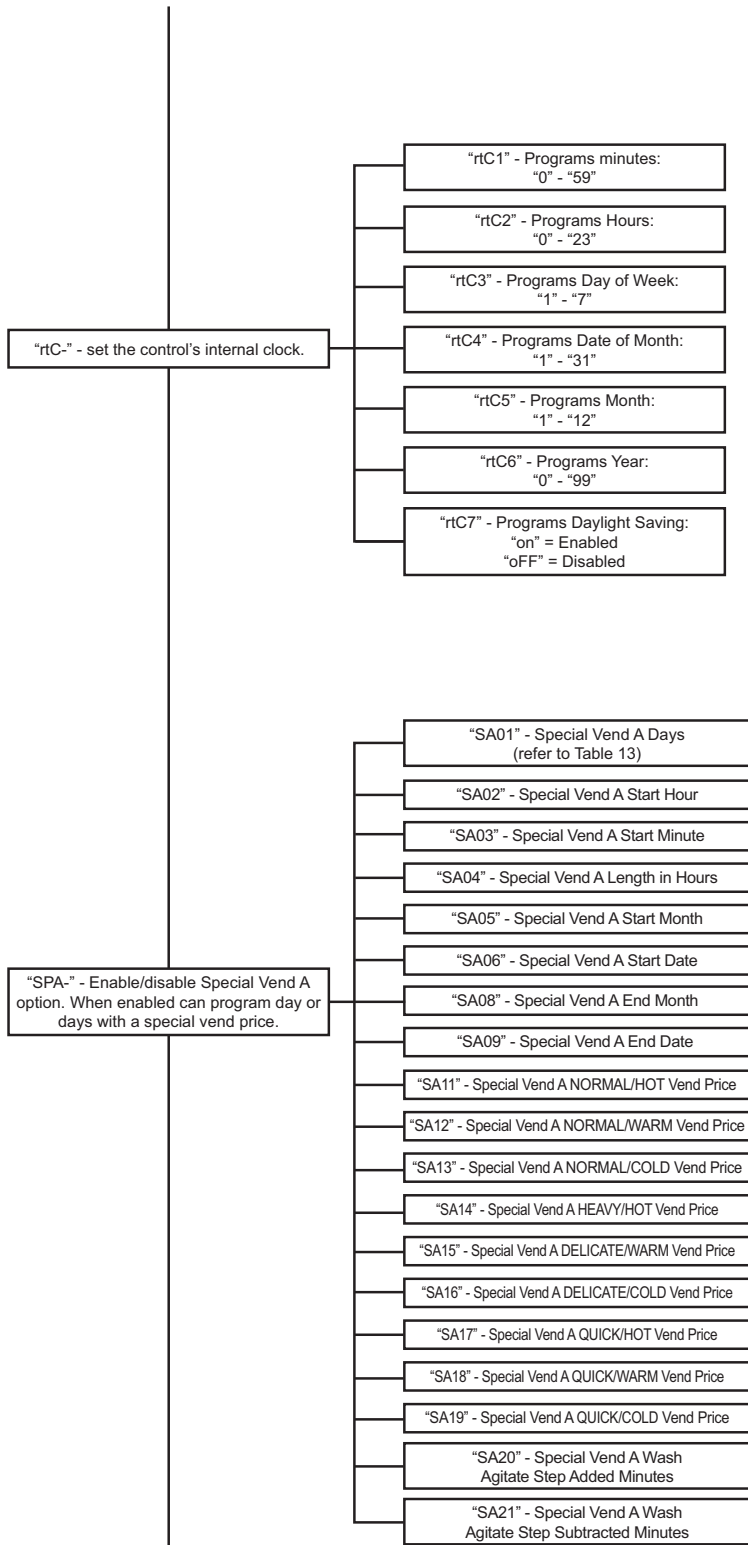

(continued)

CHM1354R

(continued)



## Programming Flowcharts

### Diagnostic

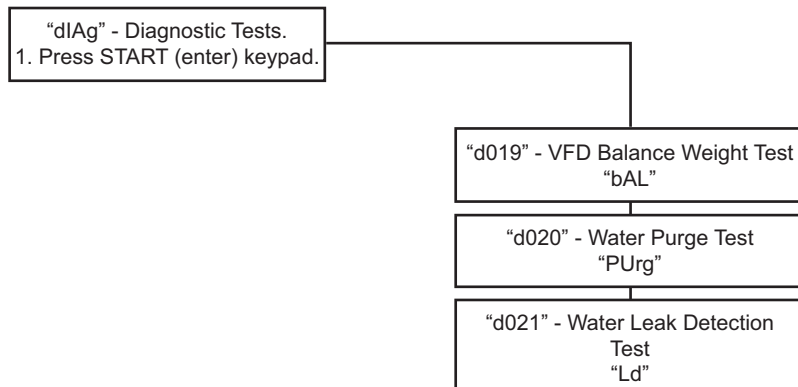

CHM531R

## 1. Normal/Hot Vend Price “AtS1”

This option allows the owner to set the vend price for a NORMAL/HOT wash. This vend price will be shown in the display when NORMAL/HOT is selected.

### How to Program the Normal/Hot Vend Price

1. Control must be in Manual Mode. Refer to *Entering the Manual Mode*.
2. Press the NORMAL/COLD (^) or the DELICATE/COLD (v) keypad until “Prog” appears in the display. Press the START (enter) keypad.
3. “AtS1” will appear in the display. Press the START (enter) keypad. The NORMAL/HOT LED will be lit to show which cycle/temperature price is being programmed.
4. There are five digits in Normal/Hot Vend Price. The fifth digit will appear in the display and will flash one (1) second on, one (1) second off. Refer to *Figure 3*.

**NOTE: If the vend price is \$100.00 or more, the fifth digit is “1-6”. If the vend price is \$99.99 or less, the fifth digit is “0”.**

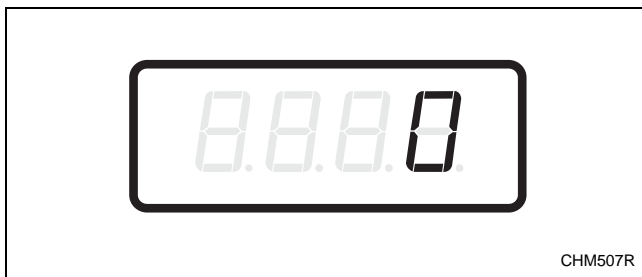

Figure 3

5. Press the NORMAL/COLD (^) or the DELICATE/COLD (v) keypad to increase or decrease the value of the fifth digit.

**NOTE: The vend price can be set from 0 to 65,535. The default vend price is 200.**

6. Press the START (enter) keypad to enter the fifth digit and display remaining four digits. The active digit will flash one (1) second on and one (1) second off.

**NOTE: To go back to the current programmable option without changing the value of the active digit, press the DELICATE/WARM (<) keypad.**

7. Press the NORMAL/COLD (^) or the DELICATE/COLD (v) keypad to increase or decrease the value of the active digit and the START (enter) keypad to enter the value of the digit and advance to the next digit.
8. Press the START (enter) keypad with the last active digit. The next option, “dEn1”, will appear in the display.

**NOTE: To program “dEn1” (Coin #1 Value), refer to option 2. To program other options, refer to the appropriate section.**

### How to Exit Programming Feature

Press the DELICATE/WARM (<) keypad until the control returns to Ready Mode.

## Programming Flowcharts

### 2. Coin #1 Value “dEn1”

This option allows the owner to set a specific numerical value for a coin entered. For example, in the United States the coin value for one quarter would be measured in cents (25). Therefore, the coin value entered for one quarter would be 00025.

If the NORMAL/HOT Vend Price (*option 1*) is set for “.75”, and the Coin Value is set for “00025”, the vend price displayed will decrease by .25 for each coin entered.

#### How to Program Coin #1 Value

1. Control must be in Manual Mode. Refer to *Entering the Manual Mode*.
2. Press the NORMAL/COLD (^) or the DELICATE/COLD (v) keypad until “Prog” appears in the display. Press the START (enter) keypad and “AtS1” will appear in the display.
3. Press the NORMAL/COLD (^) or the DELICATE/COLD (v) keypad to scroll through the programmable options until “dEn1” appears in the display.
4. When “dEn1” appears in the display, press the START (enter) keypad. There are five digits in the Coin #1 Value. The fifth digit will appear in the display and will flash one (1) second on, one (1) second off. Refer to *Figure 4*.

**NOTE: If the vend price is \$100.00 or more, the fifth digit is “1-6”. If the vend price is \$99.99 or less, the fifth digit is “0”.**

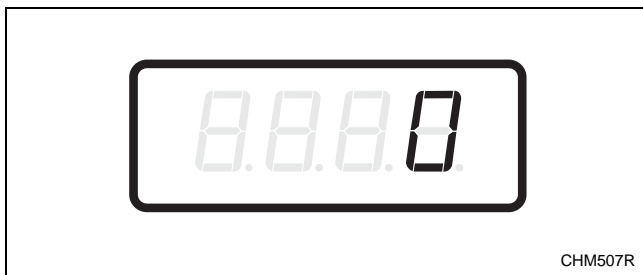

Figure 4

5. Press the NORMAL/COLD (^) or the DELICATE/COLD (v) keypad to increase or decrease the value of the fifth digit.

**NOTE: The coin value can be set from 1 to 65,535. The default coin value is 25.**

6. Press the START (enter) keypad to enter the fifth digit and display remaining four digits. The active digit will flash one (1) second on and one (1) second off.

**NOTE: To go back to the current programmable option without changing the value of the active digit, press the DELICATE/WARM(<) keypad.**

7. Press the NORMAL/COLD (^) or the DELICATE/COLD (v) keypad to increase or decrease the value of the active digit and the START (enter) keypad to enter the value of the digit and advance to the next digit.
8. Press the START (enter) keypad with the last active digit. The next option, “dEn2”, will appear in the display.

**NOTE: To program “dEn2” (Coin #2 Value), refer to *option 3*. To program other options, refer to the appropriate section.**

#### How to Exit Programming Feature

Press the DELICATE/WARM (<) keypad until the control returns to Ready Mode.

### 3. Coin #2 Value “dEn2”

This option allows the owner to set a specific numerical value for a coin entered when using the dual coin drop. For example, the coin value for a dollar coin would be measured in cents (100). Therefore, the coin value entered for one dollar coin would be 00100.

If the NORMAL/HOT Vend Price (*option 1*) is set for “2.00”, and the Coin Value is set for “00100”, the vend price displayed will decrease by 1.00 for each dollar coin entered.

#### How to Program Coin #2 Value

1. Control must be in Manual Mode. Refer to *Entering the Manual Mode*.
2. Press the NORMAL/COLD (^) or the DELICATE/COLD (v) keypad until “Prog” appears in the display. Press the START (enter) keypad and “AtS1” will appear in the display.
3. Press the NORMAL/COLD (^) or the DELICATE/COLD (v) keypad to scroll through the programmable options until “dEn2” appears in the display.
4. When “dEn2” appears in the display, press the START (enter) keypad. There are five digits in the Coin #2 Value. The fifth digit will appear in the display and will flash one (1) second on and one (1) second off. Refer to *Figure 5*.

**NOTE: If the vend price is \$100.00 or more, the fifth digit is “1-6”. If the vend price is \$99.99 or less, the fifth digit is “0”.**



Figure 5

5. Press the NORMAL/COLD (^) or the DELICATE/COLD (v) keypad to increase or decrease the value of the fifth digit.

**NOTE: The coin value can be set from 1 to 65,535. The default coin value is 100.**

6. Press the START (enter) keypad to enter the fifth digit and display remaining four digits. The active digit will flash one (1) second on and one (1) second off.

**NOTE: To go back to the current programmable option without changing the value of the active digit, press the DELICATE/WARM (<) keypad.**

7. Press the NORMAL/COLD (^) or the DELICATE/COLD (v) keypad to increase or decrease the value of the active digit and the START (enter) keypad to enter the value of the digit and advance to the next digit.
8. Press the START (enter) keypad with the last active digit. The next option, “PLSE”, will appear in the display.

**NOTE: To program “PLSE” (Start Pulse Value), refer to *option 4*. To program other options, refer to the appropriate section.**

#### How to Exit Programming Feature

Press the DELICATE/WARM (<) keypad until the control returns to Ready Mode.

## Programming Flowcharts

### 4. Start Pulse Value “PLSE”

This option allows the owner to program the value of the Start Pulse if used for multiple pulses with an after-market central card reader or pay system. Refer to *option 5* for additional information.

#### How to Program Start Pulse Value

1. Control must be in Manual Mode. Refer to *Entering the Manual Mode*.
2. Press the NORMAL/COLD (^) or the DELICATE/COLD (v) keypad until “Prog” appears in the display. Press the START (enter) keypad and “AtS1” will appear in the display.
3. Press the NORMAL/COLD (^) or the DELICATE/COLD (v) keypad to scroll through the programmable options until “PLSE” appears in the display.
4. When “PLSE” appears in the display, press the START (enter) keypad. There are five digits in the Start Pulse Value. The fifth digit will appear in the display and will flash one (1) second on and one (1) second off. Refer to *Figure 6*.

**NOTE: If the vend price is \$100.00 or more, the fifth digit is “1-6”. If the vend price is \$99.99 or less, the fifth digit is “0”.**

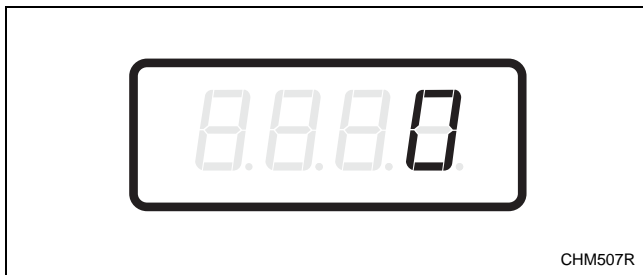

Figure 6

5. Press the NORMAL/COLD (^) or the DELICATE/COLD (v) keypad to increase or decrease the value of the fifth digit.

**NOTE: The Start Pulse Value can be set from 1 to 65,535. The default Start Pulse Value is 25.**

6. Press the START (enter) keypad to enter the fifth digit and display remaining four digits. The active digit will flash one (1) second on and one (1) second off.

**NOTE: To go back to the current programmable option without changing the value of the active digit, press the DELICATE/WARM (<) keypad.**

7. Press the NORMAL/COLD (^) or the DELICATE/COLD (v) keypad to increase or decrease the value of the active digit and the START (enter) keypad to enter the value of the digit and advance to the next digit.
8. Press the START (enter) keypad with the last active digit. The next option, “PLSn”, will appear in the display.

**NOTE: To program “PLSn” (Start Pulse Mode), refer to *option 5*. To program other options, refer to the appropriate section.**

#### How to Exit Programming Feature

Press the DELICATE/WARM (<) keypad until the control returns to Ready Mode.

## 5. Start Pulse Mode “PLSn”

This option allows the owner to program the Start Pulse Input. The Start Pulse Mode can be used for after-market central pay or card systems. The central system sends the start pulse to the Start Pulse Input of the control to start the cycle. If set for single pulse, one start pulse from the central system will put the control in Start Mode. If set for multiple pulses, each pulse will deduct from the vend price value set up in *option 4 (Start Pulse Value)* until the vend is satisfied.

### How to Program Start Pulse Mode

1. Control must be in Manual Mode. Refer to *Entering the Manual Mode*.
2. Press the NORMAL/COLD (^) or the DELICATE/COLD (v) keypad until “Prog” appears in the display. Press the START (enter) keypad and “AtS1” will appear in the display.
3. Press the NORMAL/COLD (^) or the DELICATE/COLD (v) keypad to scroll through the programmable options until “PLSn” appears in the display.
4. When “PLSn” appears in the display, press the START (enter) keypad. “oFF” or a number will appear in the display. This number corresponds to the current Start Pulse Mode Programming Value.

5. Locate the desired number in the first column of *Table 2* below.

“PLSn”		
Start Pulse Mode Value	Start Pulse ON/OFF	Single Pulse/ Multiple Pulses
“oFF”	OFF	OFF
128*	ON	Single Pulse
192	ON	Multiple Pulses

\*Factory default setting

Table 2

6. Press the NORMAL/COLD (^) or the DELICATE/COLD (v) keypad to increase or decrease the current number until correct.

**NOTE: To go back to the current programmable option without changing the current value, press the DELICATE/WARM (<) keypad.**

7. Press the START (enter) keypad when the correct number appears in the display.

**NOTE: To program “AtyP” (Available Type), refer to *option 6*. To program other options, refer to the appropriate section.**

### How to Exit Programming Feature

Press the DELICATE/WARM (<) keypad until the control returns to Ready Mode.

## 6. Available Type “AtyP”

This option allows the owner to program when the control provides an available output for card and central pay systems.

### How to Program Available Type

1. Control must be in Manual Mode. Refer to *Entering the Manual Mode*.
2. Press the NORMAL/COLD (^) or the DELICATE/COLD (v) keypad until “Prog” appears in the display. Press the START (enter) keypad and “AtS1” will appear in the display.
3. Press the NORMAL/COLD (^) or the DELICATE/COLD (v) keypad to scroll through the programmable options until “AtyP” appears in the display.
4. When “AtyP” appears in the display, press the START (enter) keypad. A number will appear in the display. This number corresponds to the current Available Type Value.
5. Press the NORMAL/COLD (^) or the DELICATE/COLD (v) keypad to increase or decrease the current number to the desired number selected from *Table 3*.

Available Type Value	Mode(s) in Which Available Signal is Active
0*	Ready Mode only
1	Ready Mode, Partial Vend Mode
2	Ready Mode, End of Cycle Mode
3	Ready Mode, End of Cycle Mode, Partial Vend Mode

\*Factory default setting

Table 3

6. Press the START (enter) keypad when the correct number appears in the display. The next option, “dCYC”, will appear in the display.

**NOTE: To program “dCYC” (Default Cycle), refer to option 7. To program other options, refer to the appropriate section.**

### How to Exit Programming Feature

Press the DELICATE/WARM (<) keypad until the control returns to Ready Mode.

## 7. Default Cycle “dCYC”

This option allows the owner to set the default cycle and temperature the machine will enter when in the Ready Mode. When programming the default cycle, refer to *Table 4*.

### How to Program Default Cycle

1. Control must be in Manual Mode. Refer to *Entering the Manual Mode*.
2. Press the NORMAL/COLD (^) or the DELICATE/COLD (v) keypad until “Prog” appears in the display. Press the START (enter) keypad and “AtS1” will appear in the display.
3. Press the NORMAL/COLD (^) or the DELICATE/COLD (v) keypad to scroll through the programmable options until “dCYC” appears in the display.
4. When “dCYC” appears in the display, press the START (enter) keypad. A number will appear in the display. This number corresponds to the current default cycle value. Refer to *Table 4*.
5. Press the NORMAL/COLD (^) or the DELICATE/COLD (v) keypad to increase or decrease the current number to the desired number selected from *Table 4*.
6. Press the START (enter) keypad when the correct number appears in the display. The next option, “oPL”, will appear in the display.

**NOTE: To program “oPL” (OPL Mode), refer to option 8. To program other options, refer to the appropriate section.**

### How to Exit Programming Feature

Press the DELICATE/WARM (<) keypad until the control returns to Ready Mode.

### How to Read *Table 4*

To determine the correct number required to program Default Cycle, use the following table. The Default Value column contains the number required in step 5. The other column corresponds to cycle type.

“dCYC”	
Default Value	Cycle Type
1	Normal/Hot
2	Normal/Warm
3	Normal/Cold
4	Heavy/Hot
5*	Delicate/Warm
6	Delicate/Cold
7	Quick/Hot
8	Quick/Warm
9	Quick/Cold

\*Factory default setting

Table 4

### 8. OPL Mode Enable/Disable “oPL”

This option allows the owner to enable or disable the OPL Mode in which no vend price needs to be satisfied to operate the machine.

#### How to Program the OPL Mode Enable/Disable

1. Control must be in Manual Mode. Refer to *Entering the Manual Mode*.
2. Press the NORMAL/COLD (^) or the DELICATE/COLD (v) keypad until “Prog” appears in the display. Press the START (enter) keypad and “AtS1” will appear in the display.
3. Press the NORMAL/COLD (^) or the DELICATE/COLD (v) keypad to scroll through the programmable options until “oPL” appears in the display.

4. When “oPL” appears in the display, press the START (enter) keypad. The current OPL Mode Enable/Disable status will appear in the display.  
“on” = Option Enabled  
“oFF” = Option Disabled (Default Setting)
5. Press the NORMAL/COLD (^) or the DELICATE/COLD (v) keypad to change the current status.
6. Press the START (enter) keypad when the desired status appears in the display. The next option, “AUd”, will appear in the display.

**NOTE: To program “AUd” (Audio Signal), refer to option 9. To program other options, refer to the appropriate section.**

#### How to Exit Programming Feature

Press the DELICATE/WARM (<) keypad until the control returns to Ready Mode.

## 9. Audio Signal “AUd”

This option allows the owner to program when the signal will sound.

There are five occasions when a signal may sound during operation. These five occasions are listed below:

### 1. End of Cycle Signal

By default, the signal is turned off. If turned on, the signal will sound for three (3) seconds at the end of a cycle.

### 2. Keypad Depression Signal

By default, this signal is turned on and will sound for a quarter of a second. This signal will sound each time a keypad is pressed.

### 3. Coin Input/Card Insertion Signal

By default, this signal is turned on and will sound for a quarter of a second each time a coin or card is entered.

### 4. Remove Card Signal (Card Models Only)

By default, this signal is turned on and will sound one (1) second on and one (1) second off when the control is prompting for card removal.

### 5. Signal for Start

By default, this signal is turned on and will sound one (1) second on and one (1) second off for 10 seconds after vend price has been satisfied.

4. When “AUd” appears in the display press the START (enter) keypad. A number will appear in the display. This number corresponds to the current Audio Signal Programming Value.
5. Locate the desired number in the first column of *Table 5* on the following page.
6. Press the NORMAL/COLD (^) or the DELICATE/COLD (v) keypad to increase or decrease the current number until correct.

**For Example:** A user might wish to have the signal sound only when a keypad is pressed. Entering the number “1” in step 5 would turn off all the options except KEYPAD. In this instance, the signal would sound only when a keypad is pressed.

7. Press the START (enter) keypad when the correct number appears in the display. The next option, “CArd”, will appear in the display.

**NOTE: To program “CArd” (Card Reader Display Control), refer to *option 10*. To program other options, refer to the appropriate section.**

## How to Exit Programming Feature

Press the DELICATE/WARM (<) keypad until the control returns to Ready Mode.

## How to Program the Audio Signal

1. Control must be in Manual Mode. Refer to *Entering the Manual Mode*.
2. Press the NORMAL/COLD (^) or the DELICATE/COLD (v) keypad until “Prog” appears in the display. Press the START (enter) keypad and “AtS1” will appear in the display.
3. Press the NORMAL/COLD (^) or the DELICATE/COLD (v) keypad to scroll through the programmable options until “AUd” appears in the display.

## Programming Flowcharts

### How to Read *Table 5*

To determine the correct number required to program the Audio Signal, use the following chart. The Signal Value column contains the number required in step 6. The other columns correspond to individual options.

Each column of options contains a unique combination of the words “ON” and “OFF” that indicates if that column’s option is turned on or off when the Signal Value is entered. Select the desired combination of options and enter the number found in the Signal Value column.

Signal Value	Start Mode	Remove Card	Coin/ Card Input	End of Cycle	Key Pressed
0	OFF	OFF	OFF	OFF	OFF
1	OFF	OFF	OFF	OFF	ON
2	OFF	OFF	OFF	ON	OFF
3	OFF	OFF	OFF	ON	ON
4	OFF	OFF	ON	OFF	OFF
5	OFF	OFF	ON	OFF	ON
6	OFF	OFF	ON	ON	OFF
7	OFF	OFF	ON	ON	ON
8	OFF	ON	OFF	OFF	OFF
9	OFF	ON	OFF	OFF	ON
10	OFF	ON	OFF	ON	OFF
11	OFF	ON	OFF	ON	ON
12	OFF	ON	ON	OFF	OFF
13	OFF	ON	ON	OFF	ON
14	OFF	ON	ON	ON	OFF
15	OFF	ON	ON	ON	ON
16	ON	OFF	OFF	OFF	OFF
17	ON	OFF	OFF	OFF	ON
18	ON	OFF	OFF	ON	OFF
19	ON	OFF	OFF	ON	ON
20	ON	OFF	ON	OFF	OFF
21	ON	OFF	ON	OFF	ON
22	ON	OFF	ON	ON	OFF
23	ON	OFF	ON	ON	ON
24	ON	ON	OFF	OFF	OFF
25	ON	ON	OFF	OFF	ON
26	ON	ON	OFF	ON	OFF
27	ON	ON	OFF	ON	ON
28	ON	ON	ON	OFF	OFF
29*	ON	ON	ON	OFF	ON
30	ON	ON	ON	ON	OFF
31	ON	ON	ON	ON	ON

\*Factory default setting

Table 5

## 10. Card Reader Display Control “CArd”

This option allows the owner to program whether the display is controlled by the machine’s electronic control or by the card reader.

**NOTE: This feature does not need to be programmed manually. The card reader itself makes this determination.**

### How to Program the Card Reader Display Control

1. Control must be in Manual Mode. Refer to *Entering the Manual Mode*.
2. Press the NORMAL/COLD (^) or the DELICATE/COLD (v) keypad until “Prog” appears in the display. Press the START (enter) keypad and “AtS1” will appear in the display.
3. Press the NORMAL/COLD (^) or the DELICATE/COLD (v) keypad to scroll through the programmable options until “CArd” appears in the display.

4. When “CArd” appears in the display, press the START (enter) keypad. The current Card Reader Display Control Status will appear in the display.  
 “on” = Card Reader controls display  
 “oFF” = Machine Electronic Control controls display (Default Setting)
5. Press the NORMAL/COLD (^) or the DELICATE/COLD (v) keypad to change the current status.
6. Press the START (enter) keypad when the desired status appears in the display. The next option, “Err-”, will appear in the display.

**NOTE: To program “Err-” (Error Code Programming), refer to *option 11*. To program other options, refer to the appropriate section.**

### How to Exit Programming Feature

Press the DELICATE/WARM (<) keypad until the control returns to Ready Mode.

## 11. Error Code Programming “Err-”

This option allows the owner to turn on or turn off certain errors in the control.

### How to Program Error Code Programming

- Control must be in Manual Mode. Refer to *Entering the Manual Mode*.
- Press the NORMAL/COLD (^) or the DELICATE/COLD (v) keypad until “Prog” appears in the display. Press the START (enter) keypad and “AtS1” will appear in the display.
- Press the NORMAL/COLD (^) or the DELICATE/COLD (v) keypad to scroll through the programmable options until “Err-” appears in the display.
- When “Err-” appears in the display, press the START (enter) keypad. Refer to *Table 6* for a list of programmable error code parameters.
- Press the NORMAL/COLD (^) or the DELICATE/COLD (v) keypad to select error code.
- Press the START (enter) keypad when the correct code appears in the display. The current status will appear in the display.
- “OFF” indicates the option is disabled. “ON” indicates the option is enabled. Press the NORMAL/COLD (^) or the DELICATE/COLD (v) keypad to change the status.
- Press the START (enter) keypad when the correct status appears in the display. The next Error Code Programming option will appear in the display.

**NOTE: To program “CyC-” (Cycle Programming), press the DELICATE/WARM (<) keypad, then the NORMAL/COLD (^) keypad and refer to *option 12*. To program other options, refer to the appropriate section.**

### How to Exit Programming Feature

Press the DELICATE/WARM(<) keypad until the control returns to Ready Mode.

“CEr-”	<b>Coin Error Parameters</b>	
	“CEr1”	Coin Error - Determines if display will show error.
	“CEr2”	Coin Error Penalty - If enabled, coin error will erase previous coins entered and reset the vend price.
	“CEr3”	Coin Drops Header Present Error - If enabled and coin drop header is unplugged, control ignores coin inputs.
“E FL”	<b>Fill Error</b>	
“E dr”	<b>Drain Error</b>	
“E Ub”	<b>Unbalance Error Display (VFD only)</b>	
“E oP”	<b>Open Thermistor Error Display (Models with Heat)</b>	
“E SH”	<b>Shorted Thermistor Error Display (Models with Heat)</b>	
“E Ht”	<b>Heat Error Display (Heater only)</b>	
“LEr-”	<b>Leak Detection Error</b> If Water Leak Detection during a machine cycle is enabled, then, on the enabled day(s) of the week, the control will check for water leaks during running machine cycles. If a leak is detected, the control will display the “E Ld” error for one minute after the cycle is completed. It will also light the right-most decimal point on the display. The Water Leak Detection diagnostic test can be used to verify the leak.	
	“LEr1”	Water Leak Detection During a Machine Cycle - Determines if water level drops below target level.
	“LEr2”	Water Leak Detection During a Machine Cycle Day of Week Enable (Refer to <i>Table 7</i> )
	“LEr3”	Number of cycles between leak detection tests.
“E Sd”	<b>Slow Drain Detection – Determines if machine is draining slower than normal.</b> If Slow Drain Detection is enabled, the control will check for slow drain operation during running machine cycles. If a slow drain is detected, the control will display the “E Sd” error for one minute after the cycle is completed. It will also light the right-most decimal point on the display.	

Table 6

Day(s) of the Week Enabled Values							
Day Of Week Value	SAT	FRI	THUR	WED	TUE	MON	SUN
0	OFF	OFF	OFF	OFF	OFF	OFF	OFF
1	OFF	OFF	OFF	OFF	OFF	OFF	ON
2	OFF	OFF	OFF	OFF	OFF	ON	OFF
3	OFF	OFF	OFF	OFF	OFF	ON	ON
4	OFF	OFF	OFF	OFF	ON	OFF	OFF
5	OFF	OFF	OFF	OFF	ON	OFF	ON
6	OFF	OFF	OFF	OFF	ON	ON	OFF
7	OFF	OFF	OFF	OFF	ON	ON	ON
8	OFF	OFF	OFF	ON	OFF	OFF	OFF
9	OFF	OFF	OFF	ON	OFF	OFF	ON
10	OFF	OFF	OFF	ON	OFF	ON	OFF
11	OFF	OFF	OFF	ON	OFF	ON	ON
12	OFF	OFF	OFF	ON	ON	OFF	OFF
13	OFF	OFF	OFF	ON	ON	OFF	ON
14	OFF	OFF	OFF	ON	ON	ON	OFF
15	OFF	OFF	OFF	ON	ON	ON	ON
16	OFF	OFF	ON	OFF	OFF	OFF	OFF
17	OFF	OFF	ON	OFF	OFF	OFF	ON
18	OFF	OFF	ON	OFF	OFF	ON	OFF
19	OFF	OFF	ON	OFF	OFF	ON	ON
20	OFF	OFF	ON	OFF	ON	OFF	OFF
21	OFF	OFF	ON	OFF	ON	OFF	ON
22	OFF	OFF	ON	OFF	ON	ON	OFF
23	OFF	OFF	ON	OFF	ON	ON	ON
24	OFF	OFF	ON	ON	OFF	OFF	OFF
25	OFF	OFF	ON	ON	OFF	OFF	ON
26	OFF	OFF	ON	ON	OFF	ON	OFF
27	OFF	OFF	ON	ON	OFF	ON	ON
28	OFF	OFF	ON	ON	ON	OFF	OFF
29	OFF	OFF	ON	ON	ON	OFF	ON
30	OFF	OFF	ON	ON	ON	ON	OFF
31	OFF	OFF	ON	ON	ON	ON	ON
32	OFF	ON	OFF	OFF	OFF	OFF	OFF
33	OFF	ON	OFF	OFF	OFF	OFF	ON
34	OFF	ON	OFF	OFF	OFF	ON	OFF
35	OFF	ON	OFF	OFF	OFF	ON	ON
36	OFF	ON	OFF	OFF	ON	OFF	OFF
37	OFF	ON	OFF	OFF	ON	OFF	ON
38	OFF	ON	OFF	OFF	ON	ON	OFF
39	OFF	ON	OFF	OFF	ON	ON	ON
40	OFF	ON	OFF	ON	OFF	OFF	OFF

Table 7 (continued)

**Programming Flowcharts**

Table 7 (continued)

<b>Day(s) of the Week Enabled Values</b>							
<b>Day Of Week Value</b>	<b>SAT</b>	<b>FRI</b>	<b>THUR</b>	<b>WED</b>	<b>TUE</b>	<b>MON</b>	<b>SUN</b>
41	OFF	ON	OFF	ON	OFF	OFF	ON
42	OFF	ON	OFF	ON	OFF	ON	OFF
43	OFF	ON	OFF	ON	OFF	ON	ON
44	OFF	ON	OFF	ON	ON	OFF	OFF
45	OFF	ON	OFF	ON	ON	OFF	ON
46	OFF	ON	OFF	ON	ON	ON	OFF
47	OFF	ON	OFF	ON	ON	ON	ON
48	OFF	ON	ON	OFF	OFF	OFF	OFF
49	OFF	ON	ON	OFF	OFF	OFF	ON
50	OFF	ON	ON	OFF	OFF	ON	OFF
51	OFF	ON	ON	OFF	OFF	ON	ON
52	OFF	ON	ON	OFF	ON	OFF	OFF
53	OFF	ON	ON	OFF	ON	OFF	ON
54	OFF	ON	ON	OFF	ON	ON	OFF
55	OFF	ON	ON	OFF	ON	ON	ON
56	OFF	ON	ON	ON	OFF	OFF	OFF
57	OFF	ON	ON	ON	OFF	OFF	ON
58	OFF	ON	ON	ON	OFF	ON	OFF
59	OFF	ON	ON	ON	OFF	ON	ON
60	OFF	ON	ON	ON	ON	OFF	OFF
61	OFF	ON	ON	ON	ON	OFF	ON
62	OFF	ON	ON	ON	ON	ON	OFF
63	OFF	ON	ON	ON	ON	ON	ON
64	ON	OFF	OFF	OFF	OFF	OFF	OFF
65	ON	OFF	OFF	OFF	OFF	OFF	ON
66	ON	OFF	OFF	OFF	OFF	ON	OFF
67	ON	OFF	OFF	OFF	OFF	ON	ON
68	ON	OFF	OFF	OFF	ON	OFF	OFF
69	ON	OFF	OFF	OFF	ON	OFF	ON
70	ON	OFF	OFF	OFF	ON	ON	OFF
71	ON	OFF	OFF	OFF	ON	ON	ON
72	ON	OFF	OFF	ON	ON	OFF	OFF
73	ON	OFF	OFF	ON	OFF	OFF	ON
74	ON	OFF	OFF	ON	OFF	ON	OFF
75	ON	OFF	OFF	ON	OFF	ON	ON
76	ON	OFF	OFF	ON	ON	OFF	OFF
77	ON	OFF	OFF	ON	ON	OFF	ON
78	ON	OFF	OFF	ON	ON	ON	OFF
79	ON	OFF	OFF	ON	ON	ON	ON
80	ON	OFF	ON	OFF	OFF	OFF	OFF
81	ON	OFF	ON	OFF	OFF	OFF	ON
82	ON	OFF	ON	OFF	OFF	ON	OFF
83	ON	OFF	ON	OFF	OFF	ON	ON
84	ON	OFF	ON	OFF	ON	OFF	OFF

Table 7 (continued)

Table 7 (continued)

Day(s) of the Week Enabled Values							
Day Of Week Value	SAT	FRI	THUR	WED	TUE	MON	SUN
85	ON	OFF	ON	OFF	ON	OFF	ON
86	ON	OFF	ON	OFF	ON	ON	OFF
87	ON	OFF	ON	OFF	ON	ON	ON
88	ON	OFF	ON	ON	OFF	OFF	OFF
89	ON	OFF	ON	ON	OFF	OFF	ON
90	ON	OFF	ON	ON	OFF	ON	OFF
91	ON	OFF	ON	ON	OFF	ON	ON
92	ON	OFF	ON	ON	ON	OFF	OFF
93	ON	OFF	ON	ON	ON	OFF	ON
94	ON	OFF	ON	ON	ON	ON	OFF
95	ON	OFF	ON	ON	ON	ON	ON
96	ON	ON	OFF	OFF	OFF	OFF	OFF
97	ON	ON	OFF	OFF	OFF	OFF	ON
98	ON	ON	OFF	OFF	OFF	ON	OFF
99	ON	ON	OFF	OFF	OFF	ON	ON
100	ON	ON	OFF	OFF	ON	OFF	OFF
101	ON	ON	OFF	OFF	ON	OFF	ON
102	ON	ON	OFF	OFF	ON	ON	OFF
103	ON	ON	OFF	OFF	ON	ON	ON
104	ON	ON	OFF	ON	OFF	OFF	OFF
105	ON	ON	OFF	ON	OFF	OFF	ON
106	ON	ON	OFF	ON	OFF	ON	OFF
107	ON	ON	OFF	ON	OFF	ON	ON
108	ON	ON	OFF	ON	ON	OFF	OFF
109	ON	ON	OFF	ON	ON	OFF	ON
110	ON	ON	OFF	ON	ON	ON	OFF
111	ON	ON	OFF	ON	ON	ON	ON
112	ON	ON	ON	OFF	OFF	OFF	OFF
113	ON	ON	ON	OFF	OFF	OFF	ON
114	ON	ON	ON	OFF	OFF	ON	OFF
115	ON	ON	ON	OFF	OFF	ON	ON
116	ON	ON	ON	OFF	ON	OFF	OFF
117	ON	ON	ON	OFF	ON	OFF	ON
118	ON	ON	ON	OFF	ON	ON	OFF
119	ON	ON	ON	OFF	ON	ON	ON
120	ON	ON	ON	ON	OFF	OFF	OFF
121	ON	ON	ON	ON	OFF	OFF	ON
122	ON	ON	ON	ON	OFF	ON	OFF
123	ON	ON	ON	ON	OFF	ON	ON
124	ON	ON	ON	ON	ON	OFF	OFF
125	ON	ON	ON	ON	ON	OFF	ON
126	ON	ON	ON	ON	ON	ON	OFF
127*	ON	ON	ON	ON	ON	ON	ON

\*Factory default setting

Table 7

## 12. Cycle Programming “CyC-”

This option allows the owner to program different aspects for various steps in each type of cycle. There are nine cycles available for programming.

### How to Enter Cycle Programming

1. Control must be in Manual Mode. Refer to *Entering the Manual Mode*.
2. Press the NORMAL/COLD (^) or the DELICATE/COLD (v) keypad until “Prog” appears in the display. Press the START (enter) keypad and “AtS1” will appear in the display.
3. Press the NORMAL/COLD (^) or the DELICATE/COLD (v) keypad to scroll through the programmable options until “CyC-” appears in the display. Press the START (enter) keypad and “CyC1” will appear in the display.
4. Press the NORMAL/COLD (^) or the DELICATE/COLD (v) keypad to scroll through the nine cycles to program. Press the START (enter) keypad when the desired cycle appears in the display.
5. The first Cycle Programming option, “AglT”, will appear in the display.

**NOTE: To program “AglT” (Cycle Agitate), continue to next option. To program other options, press the NORMAL/COLD (^) or the DELICATE/COLD (v) keypads and refer to the appropriate section.**

### How to Exit Programming Feature

Press the DELICATE/WARM (<) keypad until the control returns to Ready Mode.

## How to Program Cycle Agitate “AglT”

This option allows the owner to program the cycle’s agitation action and speed. These options apply to the entire cycle.

1. Press the NORMAL/COLD (^) or the DELICATE/COLD (v) keypad to scroll through the programmable Cycle Programming options until “AglT” appears in the display.
2. When “AglT” appears in the display, press the START (enter) keypad. The first Cycle Agitate option will appear in the display.
3. Press the NORMAL/COLD (^) or the DELICATE/COLD (v) keypad to scroll through the programmable options. Refer to *Table 8*.
4. Press the START (enter) keypad when the desired programmable option appears in the display. The current status will appear in the display. Refer to *Table 8*.

Final Spin Step	Description	Status
“tyPE”	Agitate Type	1 = Normal 2 = Gentle
“ASPd”	Agitate Speed (VFD only)	“Lo” = Reduced Speed “rEg” = Normal Speed

Table 8

5. Press the NORMAL/COLD (^) or the DELICATE/COLD (v) keypad to change the current status.
6. Press the START (enter) keypad when the desired status appears in the display. The next Cycle Agitate option will appear in the display.

**NOTE: To program “SEg1” (Cycle Segment 1) press the DELICATE/WARM (<) keypad and continue to next Cycle Programming option. To program other options, press the DELICATE/WARM (<) keypad and refer to the appropriate section.**

### How to Exit Programming Feature

Press the DELICATE/WARM (<) keypad until the control returns to Ready Mode.

## How to Program Cycle Segment “SEg1”

There are eight programmable cycle segments. Within each segment, there are several programmable options.

1. Press the NORMAL/COLD (∧) or the DELICATE/COLD (∨) keypad to scroll through the eight programmable Cycle Segments until the desired segment appears in the display.
2. When the desired segment appears in the display, press the START (enter) keypad. “SgEn” (Segment Enable/Disable) will appear in the display.
3. Press the NORMAL/COLD (∧) or the DELICATE/COLD (∨) keypad to scroll through the Cycle Segment programmable options.

**NOTE: If the Segment Enable/Disable is programmed “OFF”, the other Cycle Segment programming options can’t be accessed.**

4. Press the START (enter) keypad when the desired Cycle Segment programmable option appears in the display.

### Programming Segment Enable/Disable

1. When “SgEn” appears in the display, press the START (enter) keypad. The current Segment Enable/Disable status will appear in the display.  
“On” = Segment is enabled  
“OFF” = Segment is disabled
2. Press the NORMAL/COLD (∧) or the DELICATE/COLD (∨) keypad to change the current status.

**NOTE: If the Segment Enable/Disable is programmed “OFF”, the other Cycle Segment programming options can’t be accessed.**

3. Press the START (enter) keypad when the desired status appears in the display. The next Cycle Segment option, “FILL”, will appear in the display.

**NOTE: To program “FILL” (Fill Step), continue to next Cycle Segment option. To program other options, press the NORMAL/COLD (∧) or the DELICATE/COLD (∨) keypads and refer to the appropriate section.**

### How to Exit Programming Feature

Press the DELICATE/WARM (<) keypad until the control returns to Ready Mode.

## Programming Fill Step

1. When “FILL” appears in the display, press the START (enter) keypad. The first Fill step programming option will appear in the display.
2. Press the NORMAL/COLD (∧) or the DELICATE/COLD (∨) keypad to scroll through the programmable Fill step options. Refer to *Table 9*.

**NOTE: Fill Step “FLEn” must be enabled to scroll through all Fill Step options.**

3. Press the START (enter) keypad when the desired option appears in the display. The current status will appear in the display. Refer to *Table 9*.

Fill Step	Description	Status
“FLEn”	Fill Step Enable/Disable	“on”/“oFF”
“FLEU”	Fill Level	“HI” = high level “nEd” = medium level “Lo” = low level
“tEnP”	Fill Temperature	“CoLd” = Cold “UArn” = Warm “Hot” = Hot (35°F - 194°F [2°C - 90°C])

Table 9

4. Press the NORMAL/COLD (∧) or the DELICATE/COLD (∨) keypad to change the current status.
5. Press the START (enter) keypad when the desired status appears in the display. The next Fill step option will appear in the display.

**NOTE: To program “SUPL” (Supply Step), continue to next Cycle Segment option. To program other options, press the NORMAL/COLD (∧) or the DELICATE/COLD (∨) keypads and refer to the appropriate section.**

### How to Exit Programming Feature

Press the DELICATE/WARM (<) keypad until the control returns to Ready Mode.

## Programming Flowcharts

### Programming Supply Step

1. When “SUPL” appears in the display, press the START (enter) keypad. The first Supply step programming option will appear in the display.
2. Press the NORMAL/COLD (^) or the DELICATE/COLD (v) keypad to scroll through the programmable Supply step options. Refer to *Table 10*.

**NOTE: Supply Step “SUEn” must be enabled to scroll through all Supply Step options.**

3. Press the START (enter) keypad when the desired option appears in the display. The current status value will appear in the display. Refer to *Table 10*.

**NOTE: For the Dispenser options, the display will show “Cx” or “Sx” depending whether or not the control is programmed as compartment-oriented or supply-oriented. Refer to *option 13 Supply/Compartment Dispenser Programming*.**

4. Press the NORMAL/COLD (^) or the DELICATE/COLD (v) keypad to change the current status/value.
5. Press the START (enter) keypad when the desired status/value appears in the display. The next Supply step option will appear in the display.

**NOTE: To program “AgSt” (Agitate Step), continue to next Cycle Segment option. If in the Dispenser Options or Supply Duration programming option, press the DELICATE/WARM (<) keypad first. To program other options, press the NORMAL/COLD (^) or the DELICATE/COLD (v) keypads and refer to the appropriate section.**

### How to Exit Programming Feature

Press the DELICATE/WARM (<) keypad until the control returns to Ready Mode.

Supply Step	Description	Status/Value
“SUEn”	Supply Step Enable/Disable	“on”/“oFF”
“dISP”	Dispenser Options	Press START (enter) to access options
“C2” or “S1”	Compartment #2/ Supply #1	“on”/“oFF”
“C3” or “S2”	Compartment #3/ Supply #2	“on”/“oFF”
“C4” or “S3”	Compartment #4/ Supply #3	“on”/“oFF”
“S4”	Supply #4	“on”/“oFF”
“SdUr”	Supply Duration	Press START (enter) to access options
“SEC”	Seconds	0-59
“nIn”	Minutes	0-9

Table 10

**Programming Agitate Step**

1. When “AgSt” appears in the display, press the START (enter) keypad. The first Agitate step programming option will appear in the display.
2. Press the NORMAL/COLD (^) or the DELICATE/COLD (v) keypad to scroll through the programmable Agitate step options. Refer to Table 11.

**NOTE: Agitate Step “AgEn” must be enabled to scroll through all Agitate Step options.**

3. Press the START (enter) keypad when the desired option appears in the display. The current status/value will appear in the display. Refer to Table 11.

Agitate Step	Description	Status/Value
“AgEn”	Agitate Step Enable/Disable	“on”/“oFF”
“AdUr”	Agitate Duration (in minutes)	1-30
“HEAT”	Heat in Agitate (If heater is present)	“oFF”, 1 or 2 1 = to target 2 = maintain

Table 11

4. Press the NORMAL/COLD (^) or the DELICATE/COLD (v) keypad to change the current status/value.
5. Press the START (enter) keypad when the desired status/value appears in the display. The next Agitate step option will appear in the display.

**NOTE: To program “drAn” (Drain Step), continue to next Cycle Segment option. To program other options, press the NORMAL/COLD (^) or the DELICATE/COLD (v) keypads and refer to the appropriate section.**

**NOTE: If drain step is disabled, the extract cycle step will not be executed.**

**How to Exit Programming Feature**

Press the DELICATE/WARM (<) keypad until the control returns to Ready Mode.

**Programming Drain Step**

1. When “drAn” appears in the display, press the START (enter) keypad. The current status will be displayed.
2. Press the NORMAL/COLD (^) or the DELICATE/COLD (v) keypad to change the current status.  
“on” = Drain step is enabled  
“oFF” = Drain step is disabled

**NOTE: Drain must be enabled to activate Extract step.**

3. Press the START (enter) keypad when the desired status appears in the display. The next Cycle Segment option, “SPIn”, will appear in the display.

**NOTE: To program “SPIn” (Extract Step), continue to next Cycle Segment option. To program other options press the NORMAL/COLD (^) or the DELICATE/COLD (v) keypads and refer to the appropriate section.**

**How to Exit Programming Feature**

Press the DELICATE/WARM (<) keypad until the control returns to Ready Mode.

## Programming Flowcharts

### Programming Extract Step

1. When “SPIn” appears in the display, press the START (enter) keypad. The first Extract step programming option will appear in the display.
2. Press the NORMAL/COLD (^) or the DELICATE/COLD (v) keypad to scroll through the programmable Extract step options. Refer to Table 12.

**NOTE: Extract Step “SPEN” must be enabled to scroll through all Extract Step options.**

3. Press the START (enter) keypad when the desired option appears in the display. The current status/value will appear in the display. Refer to Table 12.

Extract Step	Description	Status/Value
“SPEN”	Extract Step Enable/Disable	“on”/“off”
“SSEC”	Extract Seconds	0-59
“SInn”	Extract Minutes	<b>Intermediate Extract:</b> minimum step time = 30 seconds maximum step time = 3:59 minutes <b>Final Extract:</b> minimum step time = 30 seconds maximum step time = 9:59 minutes
“SSPd”	Extract Speed (VFD only)	F-speed models Speeds 1-3, V-speed models use all 5 1 = very low speed (40) 2 = low speed (80) 3 = medium speed (100) 4 = high speed (120) 5 = very high speed (140)

Table 12

4. Press the NORMAL/COLD (^) or the DELICATE/COLD (v) keypad to change the current status/value.
5. Press the START (enter) keypad when the desired status/value appears in the display. The next Cycle Segment step option, “SEg2” will appear in the display.

**NOTE: To program “Cnin” (Cycle Time), continue to next Cycle Segment Option. To program other options press the NORMAL/COLD (^) or the DELICATE/COLD (v) keypads and refer to the appropriate section.**

### How to Exit Programming Feature

Press the DELICATE/WARM (<) keypad until the control returns to Ready Mode.

### How to Program Cycle Time “Cnin”

This option allows the owner to program minutes to the cycle’s display time.

1. Press the NORMAL/COLD (^) or the DELICATE/COLD (v) keypad to scroll through the programmable Cycle Programming options until “Cnin” appears in the display.

**NOTE: The option “PCtd” Programmable Cycle Time Display must be programmed “on” to access the “Cnin” option, refer to option 24.**

2. When “Cnin” appears in the display, press the START (enter) keypad. The first cycle time value will appear in the display.
3. Press the NORMAL/COLD (^) or the DELICATE/COLD (v) keypad to change the current value.

**NOTE: The Program Cycle Time can be set from 0 to 255 minutes. The default value is 0.**

4. Press the START (enter) keypad when the desired cycle time value appears in the display.

**NOTE: Programming display time (in minutes) does not actually change time in the cycle, only to the displayed cycle time for the user.**

**NOTE: To program another cycle, repeat Cycle Programming steps. To program other options, press the NORMAL/COLD (^) or the DELICATE/COLD (v) keypad and refer to the appropriate section.**

### How to Exit Programming Feature

Press the DELICATE/WARM (<) keypad until the control returns to Ready Mode.

### 13. Supply/Compartment Dispenser Programming “SUPC”

This option allows the owner to choose between the supply dispenser or compartment dispenser.

**NOTE: Supply Dispenser must only be selected if machine is connected to an external chemical supply system.**

#### How to Program Supply/Compartment Dispenser Programming

1. Control must be in Manual Mode. Refer to *Entering the Manual Mode*.
2. Press the NORMAL/COLD (^) or the DELICATE/COLD (v) keypad until “Prog” appears in the display. Press the START (enter) keypad, and “AtS1” will appear in the display.
3. Press the NORMAL/COLD (^) or the DELICATE/COLD (v) keypad to scroll through the programmable options until “SUPC” appears in the display.
4. When “SUPC” appears in the display, press the START (enter) keypad. The current dispenser option will appear in the display.  
 “S” = Supply Dispenser  
 “C” = Compartment Dispenser (Default Setting)
5. Press the NORMAL/COLD (^) or the DELICATE/COLD (v) keypad to change the dispenser type.
6. Press the START (enter) keypad when the desired dispenser type appears in the display. The next option, “bALr” (VFD models) or “lrA” (2 speed models), will appear in the display.

**NOTE: For VFD models: To program “bALr” (Number of Balance Retries), refer to *option 14*. For 2 speed models: To program “lrA” (IR Access [on/off]), refer to *option 15*. To program other options, refer to the appropriate section.**

#### How to Exit Programming Feature

Press the DELICATE/WARM (<) keypad until the control returns to Ready Mode.

### 14. Number of Balance Retries “bALr” (Variable Frequency Drives Only)

This option allows the owner to program how many times the control will retry balancing the load before moving into Extract step.

#### How to Program Number of Balance Retries

1. Control must be in Manual Mode. Refer to *Entering the Manual Mode*.
2. Press the NORMAL/COLD (^) or the DELICATE/COLD (v) keypad until “Prog” appears in the display. Press the START (enter) keypad, and “AtS1” will appear in the display.
3. Press the NORMAL/COLD (^) or the DELICATE/COLD (v) keypad to scroll through the programmable options until “bALr” appears in the display.
4. When “bALr” appears in the display, press the START (enter) keypad. The current value will appear in the display.
5. Press the NORMAL/COLD (^) or the DELICATE/COLD (v) keypad to increase or decrease the current value.

**NOTE: The number of balance retries can be set from 1-7. Default number of balance retries is 3.**

6. Press the START (enter) keypad when the desired value appears in the display. The next option, “lrA”, will appear in the display.

**NOTE: To program “lrA” (IR Access [on/off]), refer to *option 15*. To program other options, refer to the appropriate section.**

#### How to Exit Programming Feature

Press the DELICATE/WARM (<) keypad until the control returns to Ready Mode.

## 15. IR Access (On/Off) “IrA”

This option allows the owner to enable or disable allowing the control to be read by an external device.

### How to Program the IR Access (On/Off)

1. Control must be in Manual Mode. Refer to *Entering the Manual Mode*.
2. Press the NORMAL/COLD (^) or the DELICATE/COLD (v) keypad until “Prog” appears in the display. Press the START (enter) keypad and “AtS1” will appear in the display.
3. Press the NORMAL/COLD (^) or the DELICATE/COLD (v) keypad to scroll through the programmable options until “IrA” appears in the display.
4. When “IrA” appears in the display, press the START (enter) keypad. The current IR Access status will appear in the display.  
“On” = Option Enabled (Default Setting)  
“OFF” = Option Disabled
5. Press the NORMAL/COLD (^) or the DELICATE/COLD (v) keypad to change the current status.
6. Press the START (enter) keypad when the desired status appears in the display. The next option, “t FC” (Models with Heat) or “PtEn” (Non-heat Models), will appear in the display.

**NOTE: For Models with Heat: To program “t FC” (Fahrenheit/Celsius), refer to *option 16*. For Non-heat Models: To program “PtEn” (Production Test Cycle [On/Off]), refer to *option 21*. To program other options, refer to the appropriate section.**

### How to Exit Programming Feature

Press the DELICATE/WARM (<) keypad until the control returns to Ready Mode.

## 16. Fahrenheit/Celsius “t FC” (Models with Heat)

This option allows the owner to set whether the display will be shown in Fahrenheit or Celsius.

### How to Program Fahrenheit/Celsius

1. Control must be in Manual Mode. Refer to *Entering the Manual Mode*.
2. Press the NORMAL/COLD (^) or the DELICATE/COLD (v) keypad until “Prog” appears in the display. Press the START (enter) keypad and “AtS1” will appear in the display.
3. Press the NORMAL/COLD (^) or the DELICATE/COLD (v) keypad to scroll through the programmable options until “t FC” appears in the display.
4. When “t FC” appears in the display, press the START (enter) keypad. A number will appear in the display. This number (found below) corresponds to the current Fahrenheit/Celsius setting.  
“CEL” = Celsius  
“FAHr” = Fahrenheit (Default Setting)
5. Press the NORMAL/COLD (^) or the DELICATE/COLD (v) keypad to increase or decrease the current number to the desired number.
6. Press the START (enter) keypad when the correct number of degrees appears in the display. The new value is saved and the next option, “FH”, will appear in the display.

**NOTE: To program “FH” (Hot Water Temperature), refer to *option 17*. To program other options, refer to the appropriate section.**

### How to Exit Programming Feature

Press the DELICATE/WARM (<) keypad until the control returns to Ready Mode.

## 17. Hot Water Temperature “FH”

This option allows the owner to program the hot water temperature for models equipped with heat.

### How to Program Hot Water Temperature

1. Control must be in Manual Mode. Refer to *Entering the Manual Mode*.
2. Press the NORMAL/COLD (^) or the DELICATE/COLD (v) keypad until “Prog” appears in the display. Press the START (enter) keypad and “AtS1” will appear in the display.
3. Press the NORMAL/COLD (^) or the DELICATE/COLD (v) keypad to scroll through the programmable options until “FH” appears in the display.
4. When “FH” appears in the display, press the START (enter) keypad. A number will appear in the display. This number corresponds to the current Hot Water Temperature value.
5. Press the NORMAL/COLD (^) or the DELICATE/COLD (v) keypad to increase or decrease the current Hot Water Temperature value to the desired Hot Water Temperature value.

**NOTE: Hot Water Temperature is selectable between 35° and 194° Fahrenheit (2° and 90° Celsius). Default temperature is 140° Fahrenheit (60° Celsius).**

	<b>WARNING</b>
<p><b>To prevent personal injury, avoid contact with inlet water temperatures higher than 125° Fahrenheit (51° Celsius) and hot surfaces.</b></p>	
W748	

**NOTE: Refer to option 16 to select Celsius or Fahrenheit display.**

6. Press the START (enter) keypad when the correct number appears in the display. The next option, “FHC”, will appear in the display.

**NOTE: To program “FHC” (Warm Water Temperature), refer to option 18. To program other options, refer to the appropriate section.**

### How to Exit Programming Feature

Press the DELICATE/WARM (<) keypad until the control returns to Ready Mode.

## 18. Warm Water Temperature “FHC”

This option allows the owner to program the warm water temperature for models equipped with heat.

### How to Program Warm Water Temperature

1. Control must be in Manual Mode. Refer to *Entering the Manual Mode*.
2. Press the NORMAL/COLD (^) or the DELICATE/COLD (v) keypad until “Prog” appears in the display. Press the START (enter) keypad and “AtS1” will appear in the display.
3. Press the NORMAL/COLD (^) or the DELICATE/COLD (v) keypad to scroll through the programmable options until “FHC” appears in the display.
4. When “FHC” appears in the display, press the START (enter) keypad. A number will appear in the display. This number corresponds to the current Warm Water Temperature value.
5. Press the NORMAL/COLD (^) or the DELICATE/COLD (v) keypad to increase or decrease the current Warm Water Temperature value to the desired Warm Water Temperature value.

**NOTE: Warm Water Temperature is selectable between 35° and 194° Fahrenheit (2° and 90° Celsius). Default temperature is 100° Fahrenheit (38° Celsius).**

	<b>WARNING</b>
<p><b>To prevent personal injury, avoid contact with inlet water temperatures higher than 125° Fahrenheit (51° Celsius) and hot surfaces.</b></p>	
W748	

**NOTE: Refer to option 16 to select Celsius or Fahrenheit display.**

6. Press the START (enter) keypad when the correct number appears in the display. The next option, “FC”, will appear in the display.

**NOTE: To program “FC” (Cold Water Temperature), refer to option 19. To program other options, refer to the appropriate section.**

### How to Exit Programming Feature

Press the DELICATE/WARM (<) keypad until the control returns to Ready Mode.

## 19. Cold Water Temperature “FC”

This option allows the owner to program the cold water temperature for models equipped with heat.

### How to Program Cold Water Temperature

1. Control must be in Manual Mode. Refer to *Entering the Manual Mode*.
2. Press the NORMAL/COLD (∧) or the DELICATE/COLD (∨) keypad until “Prog” appears in the display. Press the START (enter) keypad and “AtS1” will appear in the display.
3. Press the NORMAL/COLD (∧) or the DELICATE/COLD (∨) keypad to scroll through the programmable options until “FC” appears in the display.
4. When “FC” appears in the display, press the START (enter) keypad. A number will appear in the display. This number corresponds to the current Cold Water Temperature value.
5. Press the NORMAL/COLD (∧) or the DELICATE/COLD (∨) keypad to increase or decrease the current Cold Water Temperature value to the desired Cold Water Temperature value.

**NOTE: Cold Water Temperature is selectable between 35° and 194° Fahrenheit (2° and 90° Celsius). Default temperature value is 35° Fahrenheit (2° Celsius).**

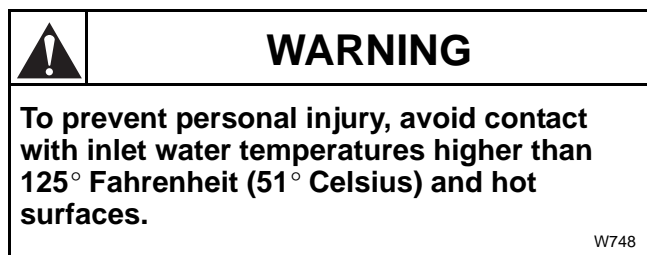

**NOTE: Refer to *option 16* to select Celsius or Fahrenheit display.**

6. Press the START (enter) keypad when the correct number appears in the display. The next option, “Codn”, will appear in the display.

**NOTE: To program “Codn” (Cooldown Enable/Temperature), refer to *option 20*. To program other options, refer to the appropriate section.**

### How to Exit Programming Feature

Press the DELICATE/WARM (<) keypad until the control returns to Ready Mode.

## 20. Cooldown Enable/Temperature “Codn” (Models with Heat)

This option allows the owner to enable or disable the Cooldown Water Temperature option. If enabled, the owner can also set the cooldown water temperature.

### How to Program Cooldown Enable/Temperature

1. Control must be in Manual Mode. Refer to *Entering the Manual Mode*.
2. Press the NORMAL/COLD (∧) or the DELICATE/COLD (∨) keypad until “Prog” appears in the display. Press the START (enter) keypad and “AtS1” will appear in the display.
3. Press the NORMAL/COLD (∧) or the DELICATE/COLD (∨) keypad to scroll through the programmable options until “Codn” appears in the display.
4. When “Codn” appears in the display, press the START (enter) keypad. A number, or “OFF”, will appear in the display. The number corresponds to the current Cooldown Water Temperature value, and “OFF” appears when cooldown is disabled.
5. Press the NORMAL/COLD (∧) or the DELICATE/COLD (∨) keypad to change the current status.

**NOTE: Cooldown Water Temperature is selectable between 50° and 160° Fahrenheit (10° and 71° Celsius). Default temperature value is OFF.**

6. Press the START (enter) keypad when the desired value appears in the display.

**NOTE: Refer to *option 16* to select Celsius or Fahrenheit display.**

7. Press the START (enter) keypad when the correct number appears in the display. The next option, “PtEn”, will appear in the display.

**NOTE: To program “PtEn” (Prouction Test Cycle [on/off]), refer to *option 21*. To program other options, refer to the appropriate section.**

### How to Exit Programming Feature

Press the DELICATE/WARM (<) keypad until the control returns to Ready Mode.

## 21. Production Test Cycle (On/Off) “PtEn”

This option allows the owner to enable or disable access to the production test cycle. Refer to *Production Test Cycle* section for more information.

### How to Program the Production Test Cycle (On/Off)

1. Control must be in Manual Mode. Refer to *Entering the Manual Mode*.
2. Press the NORMAL/COLD (^) or the DELICATE/COLD (v) keypad until “Prog” appears in the display. Press the START (enter) keypad and “AtS1” will appear in the display.
3. Press the NORMAL/COLD (^) or the DELICATE/COLD (v) keypad to scroll through the programmable options until “PtEn” appears in the display.
4. When “PtEn” appears in the display, press the START (enter) keypad. The current Production Test Cycle status will appear in the display.  
“on” = Option Enabled (Default Setting)  
“oFF” = Option Disabled
5. Press the NORMAL/COLD (^) or the DELICATE/COLD (v) keypad to change the current status.
6. Press the START (enter) keypad when the desired status appears in the display. The next option, “rAEn”, will appear in the display.

**NOTE: To program “rAEn” (Manual Rapid Advance [on/off]), refer to *option 22*. To program other options, refer to the appropriate section.**

### How to Exit Programming Feature

Press the DELICATE/WARM (<) keypad until the control returns to Ready Mode.

## 22. Manual Rapid Advance (On/Off) “rAEn”

This option allows the owner to enable or disable the rapid advance feature. Refer to *Rapid Advance Feature* section for more information.

### How to Program the Manual Rapid Advance (On/Off)

1. Control must be in Manual Mode. Refer to *Entering the Manual Mode*.
2. Press the NORMAL/COLD (^) or the DELICATE/COLD (v) keypad until “Prog” appears in the display. Press the START (enter) keypad and “AtS1” will appear in the display.
3. Press the NORMAL/COLD (^) or the DELICATE/COLD (v) keypad to scroll through the programmable options until “rAEn” appears in the display.
4. When “rAEn” appears in the display, press the START (enter) keypad. The current Manual Rapid Advance status will appear in the display.  
“on” = Option Enabled (Default Setting)  
“oFF” = Option Disabled
5. Press the NORMAL/COLD (^) or the DELICATE/COLD (v) keypad to change the current status.
6. Press the START (enter) keypad when the desired status appears in the display. The next option, “nCtd”, will appear in the display.

**NOTE: To program “nCtd” (No Cycle Time Display), refer to *option 23*. To program other options, refer to the appropriate section.**

### How to Exit Programming Feature

Press the DELICATE/WARM (<) keypad until the control returns to Ready Mode.

## 23. No Cycle Time Display “nCtd”

This option allows the owner to enable or disable whether the cycle time will appear in the display.

### How to Program No Cycle Time Display

1. Control must be in Manual Mode. Refer to *Entering the Manual Mode*.
2. Press the NORMAL/COLD (^) or the DELICATE/COLD (v) keypad until “Prog” appears in the display. Press the START (enter) keypad and “AtS1” will appear in the display.
3. Press the NORMAL/COLD (^) or the DELICATE/COLD (v) keypad to scroll through the programmable options until “nCtd” appears in the display.
4. When “nCtd” appears in the display, press the START (enter) keypad. The current No Cycle Time Display status will appear in the display.  
“on” = Option Enabled  
“off” = Option Disabled (Default Setting)
5. Press the NORMAL/COLD (^) or the DELICATE/COLD (v) keypad to change the current status.
6. Press the START (enter) keypad when the desired status appears in the display. The next option, “PCtd”, will appear in the display.

**NOTE: To program “PCtd” (Programmable Cycle Time Display), refer to *option 24*. To program other options, refer to the appropriate section.**

### How to Exit Programming Feature

Press the DELICATE/WARM (<) keypad until the control returns to Ready Mode.

## 24. Programmable Cycle Time Display “PCtd”

This option allows the owner to program the displayed cycle time.

### How to Program Programmable Cycle Time Display

1. Control must be in Manual Mode. Refer to *Entering the Manual Mode*.
2. Press the NORMAL/COLD (^) or the DELICATE/COLD (v) keypad until “Prog” appears in the display. Press the START (enter) keypad and “AtS1” will appear in the display.
3. Press the NORMAL/COLD (^) or the DELICATE/COLD (v) keypad to scroll through the programmable options until “PCtd” appears in the display.
4. When “PCtd” appears in the display, press the START (enter) keypad. The current Programmable Cycle Time Display status will appear in the display.  
“on” = Option Enabled  
“off” = Option Disabled (Default Setting)

**NOTE: Enabling this option will not change the cycle time, only the display time for the user. Refer to option “Cnin” in Cycle Programming to program minutes to the cycle time display.**

5. Press the NORMAL/COLD (^) or the DELICATE/COLD (v) keypad to change the current status.
6. Press the START (enter) keypad when the desired status appears in the display. The next option, “SdAd”, will appear in the display.

**NOTE: To program “SdAd” (Slow Drain Detection Adjust Value), refer to *option 25*. To program other options, refer to the appropriate section.**

### How to Exit Programming Feature

Press the DELICATE/WARM (<) keypad until the control returns to Ready Mode.

## 25. Slow Drain Detection Adjust Value “SdAd”

This option allows the owner to increase or decrease the Slow Drain Detection threshold by adding additional seconds to the threshold value. When enabled, it increases the time before a Slow Drain Error will occur.

### How to Program No Cycle Time Display

1. Control must be in Manual Mode. Refer to *Entering the Manual Mode*.
2. Press the NORMAL/COLD (^) or the DELICATE/COLD (v) keypad until “Prog” appears in the display. Press the START (enter) keypad and “AtS1” will appear in the display.
3. Press the NORMAL/COLD (^) or the DELICATE/COLD (v) keypad to scroll through the programmable options until “SdAd” appears in the display.
4. When “SdAd” appears in the display, press the START (enter) keypad. The current Slow Drain Detection Adjust status will appear in the display.  
 “on” = Option Enabled  
 “oFF” = Option Disabled (Default Setting)
5. Press the NORMAL/COLD (^) or the DELICATE/COLD (v) keypad to change the current value.

**NOTE: The Slow Drain Detection Adjust Value can be set from 0 to 255 seconds.**

6. Press the START (enter) keypad when the desired value appears in the display. The next option, “SPAU”, will appear in the display.

**NOTE: To program “SPAU” (Pause/Resume Mode), refer to *option 26*. To program other options, refer to the appropriate section.**

### How to Exit Programming Feature

Press the DELICATE/WARM (<) keypad until the control returns to Ready Mode.

## 26. Pause/Resume Mode (On/Off) “SPAU”

This option allows the owner to enable or disable Pause/Resume Mode. When enabled, users can press the START keypad three times (during first three minutes of cycle) to pause the cycle.

### How to Program the Pause/Resume Mode (On/Off)

1. Control must be in Manual Mode. Refer to *Entering the Manual Mode*.
2. Press the NORMAL/COLD (^) or the DELICATE/COLD (v) keypad until “Prog” appears in the display. Press the START (enter) keypad and “AtS1” will appear in the display.
3. Press the NORMAL/COLD (^) or the DELICATE/COLD (v) keypad to scroll through the programmable options until “SPAU” appears in the display.
4. When “SPAU” appears in the display, press the START (enter) keypad. The current Pause/Resume status will appear in the display.  
 “on” = Option Enabled  
 “oFF” = Option Disabled (Default Setting)
5. Press the NORMAL/COLD (^) or the DELICATE/COLD (v) keypad to change the current status.
6. Press the START (enter) keypad when the desired status appears in the display. The next option, “AtS2”, will appear in the display.

**NOTE: To program “AtS2” (Normal/Warm Vend Price), refer to *option 27*. To program other options, refer to the appropriate section.**

### How to Exit Programming Feature

Press the DELICATE/WARM (<) keypad until the control returns to Ready Mode.

## 27. Normal/Warm Vend Price “AtS2”

This option allows the owner to set the vend price for a normal/warm wash. This vend price will be shown in the display when NORMAL/WARM is selected.

### How to Program the Normal/Warm Vend Price

1. Control must be in Manual Mode. Refer to *Entering the Manual Mode*.
2. Press the NORMAL/COLD (^) or the DELICATE/COLD (v) keypad until “Prog” appears in the display. Press the START (enter) keypad, and “AtS1” will appear in the display.
3. Press the NORMAL/COLD (^) or the DELICATE/COLD (v) keypad to scroll through the programmable options until “AtS2” appears in the display. The NORMAL/WARM LED will be lit to show which cycle/temperature price is being programmed.
4. When “AtS2” appears in the display, press the START (enter) keypad. There are five digits in the Normal/Warm Vend Price. The fifth digit will appear in the display and will flash one (1) second on, one (1) second off. Refer to *Figure 7*.

**NOTE: If the vend price is \$100.00 or more, the fifth digit is “1-6”. If the vend price is \$99.99 or less, the fifth digit is “0”.**



Figure 7

5. Press the NORMAL/COLD (^) or the DELICATE/COLD (v) keypad to increase or decrease the value of the fifth digit.

**NOTE: The vend price can be set from 0 to 65,535. Default vend price is 200.**

6. Press the START (enter) keypad to enter the fifth digit and display remaining four digits. The active digit will flash one (1) second on and one (1) second off.

**NOTE: To go back to the current programmable option without changing the value of the active digit, press the DELICATE/WARM (<) keypad.**

7. Press the NORMAL/COLD (^) or the DELICATE/COLD (v) keypad to increase or decrease the value of the active digit and the START (enter) keypad to enter the value of the digit and advance to the next digit.
8. Press the START (enter) keypad with the last active digit. The next option, “AtS3”, will appear in the display.

**NOTE: To program “AtS3” (Normal/Cold Vend Price), refer to *option 28*. To program other options, refer to the appropriate section.**

### How to Exit Programming Feature

Press the DELICATE/WARM (<) keypad until the control returns to Ready Mode.

## 28. Normal/Cold Vend Price “AtS3”

This option allows the owner to set the vend price for a normal/cold wash. This vend price will be shown in the display when NORMAL/COLD is selected.

### How to Program the Normal/Cold Vend Price

1. Control must be in Manual Mode. Refer to *Entering the Manual Mode*.
2. Press the NORMAL/COLD (^) or the DELICATE/COLD (v) keypad until “Prog” appears in the display. Press the START (enter) keypad and “AtS1” will appear in the display.
3. Press the NORMAL/COLD (^) or the DELICATE/COLD (v) keypad to scroll through the programmable options until “AtS3” appears in the display. The NORMAL/COLD LED will be lit to show which cycle/temperature price is being programmed.
4. When “AtS3” appears in the display, press the START (enter) keypad. There are five digits in the NORMAL/COLD Vend Price. The fifth digit will appear in the display and will flash one (1) second on, one (1) second off. Refer to *Figure 8*.

**NOTE: If the vend price is \$100.00 or more, the fifth digit is “1-6”. If the vend price is \$99.99 or less, the fifth digit is “0”.**



Figure 8

5. Press the NORMAL/COLD (^) or the DELICATE/COLD (v) keypad to increase or decrease the value of the fifth digit.

**NOTE: The vend price can be set from 0 to 65,535. Default vend price is 200.**

6. Press the START (enter) keypad to enter the fifth digit and display remaining four digits. The active digit will flash one (1) second on and one (1) second off.

**NOTE: To go back to the current programmable option without changing the value of the active digit, press the DELICATE/WARM (<) keypad.**

7. Press the NORMAL/COLD (^) or the DELICATE/COLD (v) keypad to increase or decrease the value of the active digit and the START (enter) keypad to enter the value of the digit and advance to the next digit.
8. Press the START (enter) keypad with the last active digit. The next option, “AtS4”, will appear in the display.

**NOTE: To program “AtS4” (Heavy/Hot Cycle Vend Price), refer to *option 29*. To program other options, refer to the appropriate section.**

### How to Exit Programming Feature

Press the DELICATE/WARM (<) keypad until the control returns to Ready Mode.

## 29. Heavy/Hot Vend Price “AtS4”

This option allows the owner to set the vend price for a perm press/hot wash. This vend price will be shown in the display when HEAVY/HOT is selected.

### How to Program the Heavy/Hot Vend Price

1. Control must be in Manual Mode. Refer to *Entering the Manual Mode*.
2. Press the NORMAL/COLD (^) or the DELICATE/COLD (v) keypad until “Prog” appears in the display. Press the START (enter) keypad and “AtS1” will appear in the display.
3. Press the NORMAL/COLD (^) or the DELICATE/COLD (v) keypad to scroll through the programmable options until “AtS4” appears in the display. The HEAVY/HOT LED will be lit to show which cycle/temperature price is being programmed.
4. When “AtS4” appears in the display, press the START (enter) keypad. There are five digits in the Heavy/Hot Vend Price. The fifth digit will appear in the display and will flash one (1) second on, one (1) second off. Refer to *Figure 9*.

**NOTE: If the vend price is \$100.00 or more, the fifth digit is “1-6”. If the vend price is \$99.99 or less, the fifth digit is “0”.**

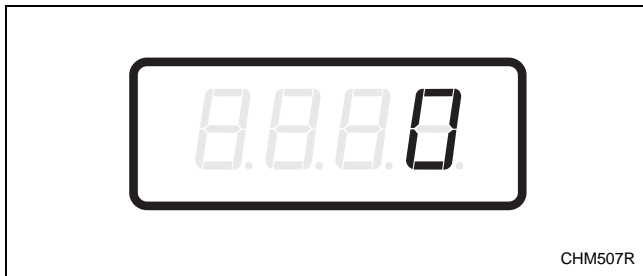

Figure 9

5. Press the NORMAL/COLD (^) or the DELICATE/COLD (v) keypad to increase or decrease the value of the fifth digit.

**NOTE: The vend price can be set from 0 to 65,535. Default vend price is 200.**

6. Press the START (enter) keypad to enter the fifth digit and display remaining four digits. The active digit will flash one (1) second on and one (1) second off.

**NOTE: To go back to the current programmable option without changing the value of the active digit, press the DELICATE/WARM (<) keypad.**

7. Press the NORMAL/COLD (^) or the DELICATE/COLD (v) keypad to increase or decrease the value of the active digit and the START (enter) keypad to enter the value of the digit and advance to the next digit.
8. Press the START (enter) keypad with the last active digit. The next option, “AtS5”, will appear in the display.

**NOTE: To program “AtS5” (Delicate/Warm Vend Price), refer to *option 30*. To program other options, refer to the appropriate section.**

### How to Exit Programming Feature

Press the DELICATE/WARM (<) keypad until the control returns to Ready Mode.

### 30. Delicate/Warm Vend Price “AtS5”

This option allows the owner to set the vend price for a perm press/warm wash. This vend price will be shown in the display when DELICATE/WARM is selected.

#### How to Program the Delicate/Warm Vend Price

1. Control must be in Manual Mode. Refer to *Entering the Manual Mode*.
2. Press the NORMAL/COLD (^) or the DELICATE/COLD (v) keypad until “Prog” appears in the display. Press the START (enter) keypad and “AtS1” will appear in the display.
3. Press the NORMAL/COLD (^) or the DELICATE/COLD (v) keypad to scroll through the programmable options until “AtS5” appears in the display. The DELICATE/WARM LED will be lit to show which cycle/temperature price is being programmed.
4. When “AtS5” appears in the display, press the START (enter) keypad. There are five digits in the Delicate/Warm Vend Price. The fifth digit will appear in the display and will flash one (1) second on, one (1) second off. Refer to *Figure 10*.

**NOTE: If the vend price is \$100.00 or more, the fifth digit is “1-6”. If the vend price is \$99.99 or less, the fifth digit is “0”.**



Figure 10

5. Press the NORMAL/COLD (^) or the DELICATE/COLD (v) keypad to increase or decrease the value of the fifth digit.

**NOTE: The vend price can be set from 0 to 65,535. Default vend price is 200.**

6. Press the START (enter) keypad to enter the fifth digit and display remaining four digits. The active digit will flash one (1) second on and one (1) second off.

**NOTE: To go back to the current programmable option without changing the value of the active digit, press the DELICATE/WARM (<) keypad.**

7. Press the NORMAL/COLD (^) or the DELICATE/COLD (v) keypad to increase or decrease the value of the active digit and the START (enter) keypad to enter the value of the digit and advance to the next digit.
8. Press the START (enter) keypad with the last active digit. The next option, “AtS6”, will appear in the display.

**NOTE: To program “AtS6” (Delicate/Cold Vend Price), refer to *option 31*. To program other options, refer to the appropriate section.**

#### How to Exit Programming Feature

Press the DELICATE/WARM (<) keypad until the control returns to Ready Mode.

### 31. Delicate/Cold Vend Price “AtS6”

This option allows the owner to set the vend price for a perm press/cold wash. This vend price will be shown in the display when DELICATE/COLD is selected.

#### How to Program the Delicate/Cold Vend Price

1. Control must be in Manual Mode. Refer to *Entering the Manual Mode*.
2. Press the NORMAL/COLD (^) or the DELICATE/COLD (v) keypad until “Prog” appears in the display. Press the START (enter) keypad and “AtS1” will appear in the display.
3. Press the NORMAL/COLD (^) or the DELICATE/COLD (v) keypad to scroll through the programmable options until “AtS6” appears in the display. The DELICATE/COLD LED will be lit to show which cycle/temperature price is being programmed.
4. When “AtS6” appears in the display, press the START (enter) keypad. There are five digits in the Delicate/Cold Vend Price. The fifth digit will appear in the display and will flash one (1) second on, one (1) second off. Refer to *Figure 11*.

**NOTE: If the vend price is \$100.00 or more, the fifth digit is “1-6”. If the vend price is \$99.99 or less, the fifth digit is “0”.**

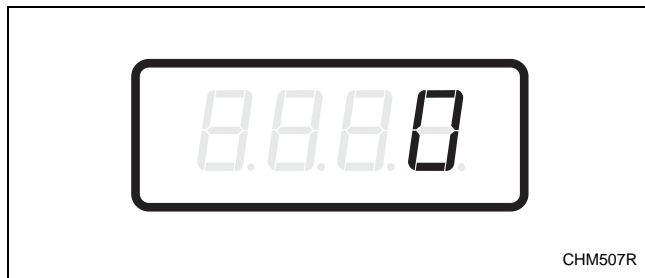

Figure 11

5. Press the NORMAL/COLD (^) or the DELICATE/COLD (v) keypad to increase or decrease the value of the fifth digit.

**NOTE: The vend price can be set from 0 to 65,535. Default vend price is 200.**

6. Press the START (enter) keypad to enter the fifth digit and display remaining four digits. The active digit will flash one (1) second on and one (1) second off.

**NOTE: To go back to the current programmable option without changing the value of the active digit, press the DELICATE/WARM (<) keypad.**

7. Press the NORMAL/COLD (^) or the DELICATE/COLD (v) keypad to increase or decrease the value of the active digit and the START (enter) keypad to enter the value of the digit and advance to the next digit.
8. Press the START (enter) keypad with the last active digit. The next option, “AtS7”, will appear in the display.

**NOTE: To program “AtS7” (Quick/Hot Vend Price), refer to option 32. To program other options, refer to the appropriate section.**

#### How to Exit Programming Feature

Press the DELICATE/WARM (<) keypad until the control returns to Ready Mode.

## 32. Quick/Hot Vend Price “AtS7”

This option allows the owner to set the vend price for a delicate/hot wash. This vend price will be shown in the display when QUICK/HOT is selected.

### How to Program the Quick/Hot Vend Price

1. Control must be in Manual Mode. Refer to *Entering the Manual Mode*.
2. Press the NORMAL/COLD (^) or the DELICATE/COLD (v) keypad until “Prog” appears in the display. Press the START (enter) keypad and “AtS1” will appear in the display.
3. Press the NORMAL/COLD (^) or the DELICATE/COLD (v) keypad to scroll through the programmable options until “AtS7” appears in the display. The QUICK/HOT LED will be lit to show which cycle/temperature price is being programmed.
4. When “AtS7” appears in the display, press the START (enter) keypad. There are five digits in the Quick/Hot Vend Price. The fifth digit will appear in the display and will flash one (1) second on, one (1) second off. Refer to *Figure 12*.

**NOTE: If the vend price is \$100.00 or more, the fifth digit is “1-6”. If the vend price is \$99.99 or less, the fifth digit is “0”.**

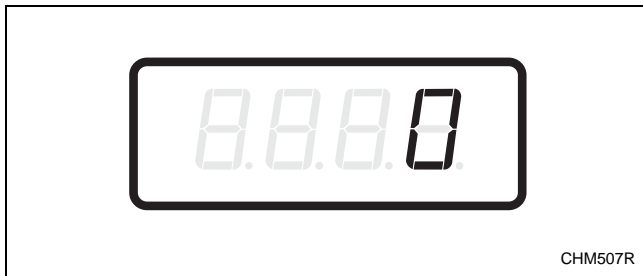

Figure 12

5. Press the NORMAL/COLD (^) or the DELICATE/COLD (v) keypad to increase or decrease the value of the fifth digit.

**NOTE: The vend price can be set from 0 to 65,535. Default vend price is 200.**

6. Press the START (enter) keypad to enter the fifth digit and display remaining four digits. The active digit will flash one (1) second on and one (1) second off.

**NOTE: To go back to the current programmable option without changing the value of the active digit, press the DELICATE/WARM (<) keypad.**

7. Press the NORMAL/COLD (^) or the DELICATE/COLD (v) keypad to increase or decrease the value of the active digit and the START (enter) keypad to enter the value of the digit and advance to the next digit.
8. Press the START (enter) keypad with the last active digit. The next option, “AtS8”, will appear in the display.

**NOTE: To program “AtS8” (Quick/Warm Vend Price), refer to *option 33*. To program other options, refer to the appropriate section.**

### How to Exit Programming Feature

Press the DELICATE/WARM (<) keypad until the control returns to Ready Mode.

### 33. Quick/Warm Vend Price “AtS8”

This option allows the owner to set the vend price for a delicate/warm wash. This vend price will be shown in the display when QUICK/WARM is selected.

#### How to Program the Quick/Warm Vend Price

1. Control must be in Manual Mode. Refer to *Entering the Manual Mode*.
2. Press the NORMAL/COLD (^) or the DELICATE/COLD (v) keypad until “Prog” appears in the display. Press the START (enter) keypad and “AtS1” will appear in the display.
3. Press the NORMAL/COLD (^) or the DELICATE/COLD (v) keypad to scroll through the programmable options until “AtS8” appears in the display. The QUICK/WARM LED will be lit to show which cycle/temperature price is being programmed.
4. When “AtS8” appears in the display, press the START (enter) keypad. There are five digits in the Quick/Warm Vend Price. The fifth digit will appear in the display and will flash one (1) second on, one (1) second off. Refer to *Figure 13*.

**NOTE: If the vend price is \$100.00 or more, the fifth digit is “1-6”. If the vend price is \$99.99 or less, the fifth digit is “0”.**



Figure 13

5. Press the NORMAL/COLD (^) or the DELICATE/COLD (v) keypad to increase or decrease the value of the fifth digit.

**NOTE: The vend price can be set from 0 to 65,535. Default vend price is 200.**

6. Press the START (enter) keypad to enter the fifth digit and display remaining four digits. The active digit will flash one (1) second on and one (1) second off.

**NOTE: To go back to the current programmable option without changing the value of the active digit, press the DELICATE/WARM (<) keypad.**

7. Press the NORMAL/COLD (^) or the DELICATE/COLD (v) keypad to increase or decrease the value of the active digit and the START (enter) keypad to enter the value of the digit and advance to the next digit.
8. Press the START (enter) keypad with the last active digit. The next option, “AtS9”, will appear in the display.

**NOTE: To program “AtS9” (Quick/Cold Vend Price), refer to *option 34*. To program other options, refer to the appropriate section.**

#### How to Exit Programming Feature

Press the DELICATE/WARM (<) keypad until the control returns to Ready Mode.

### 34. Quick/Cold Vend Price “AtS9”

This option allows the owner to set the vend price for a delicate/cold wash. This vend price will be shown in the display when QUICK/COLD is selected.

#### How to Program the Quick/Cold Vend Price

1. Control must be in Manual Mode. Refer to *Entering the Manual Mode*.
2. Press the NORMAL/COLD (^) or the DELICATE/COLD (v) keypad until “Prog” appears in the display. Press the START (enter) keypad and “AtS1” will appear in the display.
3. Press the NORMAL/COLD (^) or the DELICATE/COLD (v) keypad to scroll through the programmable options until “AtS9” appears in the display. The QUICK/COLD LED will be lit to show which cycle/temperature price is being programmed.
4. When “AtS9” appears in the display, press the START (enter) keypad. There are five digits in the Quick/Cold Vend Price. The fifth digit will appear in the display and will flash one (1) second on, one (1) second off. Refer to *Figure 14*.

**NOTE: If the vend price is \$100.00 or more, the fifth digit is “1-6”. If the vend price is \$99.99 or less, the fifth digit is “0”.**



Figure 14

5. Press the NORMAL/COLD (^) or the DELICATE/COLD (v) keypad to increase or decrease the value of the fifth digit.

**NOTE: The vend price can be set from 0 to 65,535. Default vend price is 200.**

6. Press the START (enter) keypad to enter the fifth digit and display remaining four digits. The active digit will flash one (1) second on and one (1) second off.

**NOTE: To go back to the current programmable option without changing the value of the active digit, press the DELICATE/WARM (<) keypad.**

7. Press the NORMAL/COLD (^) or the DELICATE/COLD (v) keypad to increase or decrease the value of the active digit and the START (enter) keypad to enter the value of the digit and advance to the next digit.
8. Press the START (enter) keypad with the last active digit. The next option, “rtC-”, will appear in the display.

**NOTE: To program “rtC-” (Real Time Clock), refer to *option 35*. To program other options, refer to the appropriate section.**

#### How to Exit Programming Feature

Press the DELICATE/WARM (<) keypad until the control returns to Ready Mode.

### 35. Set Real-Time Clock “rtC-”

This option allows the owner to set the control’s internal clock to the correct time and date.

#### How to Program the Time and Date

1. Control must be in Manual Mode. Refer to *Entering the Manual Mode*.
2. Press the NORMAL/COLD (^) or the DELICATE/COLD (v) keypad until “Prog” appears in the display. Press the START (enter) keypad and “AtS1” will appear in the display.
3. Press the NORMAL/COLD (^) or the DELICATE/COLD (v) keypad to scroll through the programmable options until “rtC-” appears in the display. Press the START keypad and “rtC1” will appear in the display.
4. Press the NORMAL/COLD (^) or the DELICATE/COLD (v) keypad to scroll through the programmable options. Refer to *Table 13*.

“rtC1”	Programs Minutes (0-59)
“rtC2”	Programs Hours (0-23)
“rtC3”	Programs Day of Week (1-7)
“rtC4”	Programs Date of Month (1-31)
“rtC5”	Programs Month (1-12)
“rtC6”	Programs Year (0-99)
“rtC7”	Programs Daylight Saving (ON*, OFF)

\*Factory Default Setting

Table 13

5. When the desired option appears in the display, press the START (enter) keypad. The current value will appear in the display.
6. Press the NORMAL/COLD (^) or the DELICATE/COLD (v) keypad to increase or decrease the minutes, hours, day of week, date of the month, month, year to the correct time or date.

**NOTE: The hours will be displayed in military time. For day of week, Sunday is considered day one (1), Monday is day two (2) and so on. For year, the year 2000 is “00”, the year 2001 is “01” and so on.**

If programming Daylight Saving, “rtC7”, “on” enables Daylight Saving Time and “oFF” disables Daylight Saving Time.

7. Press the START (enter) keypad when the correct time or date appears in the display. The next Set Real-Time Clock option will appear in the display.

**NOTE: To program “SPA-” (Special Vend A Data), press the DELICATE/WARM (<) keypad and refer to *option 36*. To program other options, refer to the appropriate section.**

#### How to Exit Programming Feature

Press the DELICATE/WARM (<) keypad until the control returns to Ready Mode.

### 36. Special Vend A Data “SPA-”

This option allows the owner to set the day or days of a special vend.

Special Vend A is used to change the standard vend prices for special occasions. The special vend can be programmed to start and end on a specific day or days of the week.

The owner may also turn the Special Vend A option on or off if desired.

#### How to Program Special Vend A Days Enable “SA01”

1. Control must be in Manual Mode. Refer to *Entering the Manual Mode*.
2. Press the NORMAL/COLD (^) or the DELICATE/COLD (v) keypad until “Prog” appears in the display. Press the START (enter) keypad and “AtS1” will appear in the display.
3. Press the NORMAL/COLD (^) or the DELICATE/COLD (v) keypad to scroll through the programmable options until “SPA-” appears in the display. Press the START (enter) keypad and “SA01” will appear in the display.
4. When “SA01” appears in the display, press the START (enter) keypad. A number will appear in the display that corresponds to the current Special Vend A Days Enable Programming Value.
5. Locate the desired number in the first column of *Table 14* on the following pages.
6. Press the NORMAL/COLD (^) or the DELICATE/COLD (v) keypad to increase or decrease the current number until correct.
7. Press the START (enter) keypad when the correct number appears in the display. The next Special Vend A option, “SA02”, will appear in the display.

**NOTE: To program “SA02” (Special Vend A Start Hour), continue to the next Special Vend A option. To program other options, press the DELICATE/WARM (<) keypad and refer to the appropriate section.**

#### How to Exit Programming Feature

Press the DELICATE/WARM (<) keypad until the control returns to Ready Mode.

## Programming Flowcharts

### How to Read *Table 14*

To determine the correct number required to program the Special Vend Days Enable, use the following table. The Special Vend Value column contains the number required in step 6. The other columns correspond to individual days.

Each column of days contains a unique combination of the words “ON” and “OFF” that indicates if that column’s day is turned on or off when the value is entered. Select the desired combination of days and enter the number found in the value column.

“SA01”								
SPECIAL VEND VALUE	SAT	FRI	THUR	WED	TUE	MON	SUN	ON/OFF
0*	OFF	OFF	OFF	OFF	OFF	OFF	OFF	OFF
3	OFF	OFF	OFF	OFF	OFF	OFF	ON	ON
5	OFF	OFF	OFF	OFF	OFF	ON	OFF	ON
7	OFF	OFF	OFF	OFF	OFF	ON	ON	ON
9	OFF	OFF	OFF	OFF	ON	OFF	OFF	ON
11	OFF	OFF	OFF	OFF	ON	OFF	ON	ON
13	OFF	OFF	OFF	OFF	ON	ON	OFF	ON
15	OFF	OFF	OFF	OFF	ON	ON	ON	ON
17	OFF	OFF	OFF	ON	OFF	OFF	OFF	ON
19	OFF	OFF	OFF	ON	OFF	OFF	ON	ON
21	OFF	OFF	OFF	ON	OFF	ON	OFF	ON
23	OFF	OFF	OFF	ON	OFF	ON	ON	ON
25	OFF	OFF	OFF	ON	ON	OFF	OFF	ON
27	OFF	OFF	OFF	ON	ON	OFF	ON	ON
29	OFF	OFF	OFF	ON	ON	ON	OFF	ON
31	OFF	OFF	OFF	ON	ON	ON	ON	ON
33	OFF	OFF	ON	OFF	OFF	OFF	OFF	ON
35	OFF	OFF	ON	OFF	OFF	OFF	ON	ON
37	OFF	OFF	ON	OFF	OFF	ON	OFF	ON
39	OFF	OFF	ON	OFF	OFF	ON	ON	ON
41	OFF	OFF	ON	OFF	ON	OFF	OFF	ON
43	OFF	OFF	ON	OFF	ON	OFF	ON	ON
45	OFF	OFF	ON	OFF	ON	ON	OFF	ON
47	OFF	OFF	ON	OFF	ON	ON	ON	ON
49	OFF	OFF	ON	ON	OFF	OFF	OFF	ON
51	OFF	OFF	ON	ON	OFF	OFF	ON	ON
53	OFF	OFF	ON	ON	OFF	ON	OFF	ON
55	OFF	OFF	ON	ON	OFF	ON	ON	ON
57	OFF	OFF	ON	ON	ON	OFF	OFF	ON
59	OFF	OFF	ON	ON	ON	OFF	ON	ON
61	OFF	OFF	ON	ON	ON	ON	OFF	ON
63	OFF	OFF	ON	ON	ON	ON	ON	ON
65	OFF	ON	OFF	OFF	OFF	OFF	OFF	ON
67	OFF	ON	OFF	OFF	OFF	OFF	ON	ON

\*Factory default setting

Table 14 (continued)

Table 14 (continued)

"SA01"								
SPECIAL VEND VALUE	SAT	FRI	THUR	WED	TUE	MON	SUN	ON/OFF
69	OFF	ON	OFF	OFF	OFF	ON	OFF	ON
71	OFF	ON	OFF	OFF	OFF	ON	ON	ON
73	OFF	ON	OFF	OFF	ON	OFF	OFF	ON
75	OFF	ON	OFF	OFF	ON	OFF	ON	ON
77	OFF	ON	OFF	OFF	ON	ON	OFF	ON
79	OFF	ON	OFF	OFF	ON	ON	ON	ON
81	OFF	ON	OFF	ON	OFF	OFF	OFF	ON
83	OFF	ON	OFF	ON	OFF	OFF	ON	ON
85	OFF	ON	OFF	ON	OFF	ON	OFF	ON
87	OFF	ON	OFF	ON	OFF	ON	ON	ON
89	OFF	ON	OFF	ON	ON	OFF	OFF	ON
91	OFF	ON	OFF	ON	ON	OFF	ON	ON
93	OFF	ON	OFF	ON	ON	ON	OFF	ON
95	OFF	ON	OFF	ON	ON	ON	ON	ON
97	OFF	ON	ON	OFF	OFF	OFF	OFF	ON
99	OFF	ON	ON	OFF	OFF	OFF	ON	ON
101	OFF	ON	ON	OFF	OFF	ON	OFF	ON
103	OFF	ON	ON	OFF	OFF	ON	ON	ON
105	OFF	ON	ON	OFF	ON	OFF	OFF	ON
107	OFF	ON	ON	OFF	ON	OFF	ON	ON
109	OFF	ON	ON	OFF	ON	ON	OFF	ON
111	OFF	ON	ON	OFF	ON	ON	ON	ON
113	OFF	ON	ON	ON	OFF	OFF	OFF	ON
115	OFF	ON	ON	ON	OFF	OFF	ON	ON
117	OFF	ON	ON	ON	OFF	ON	OFF	ON
119	OFF	ON	ON	ON	OFF	ON	ON	ON
121	OFF	ON	ON	ON	ON	OFF	OFF	ON
123	OFF	ON	ON	ON	ON	OFF	ON	ON
125	OFF	ON	ON	ON	ON	ON	OFF	ON
127	OFF	ON	ON	ON	ON	ON	ON	ON
129	ON	OFF	OFF	OFF	OFF	OFF	OFF	ON
131	ON	OFF	OFF	OFF	OFF	OFF	ON	ON
133	ON	OFF	OFF	OFF	OFF	ON	OFF	ON
135	ON	OFF	OFF	OFF	OFF	ON	ON	ON
137	ON	OFF	OFF	OFF	ON	OFF	OFF	ON
139	ON	OFF	OFF	OFF	ON	OFF	ON	ON
141	ON	OFF	OFF	OFF	ON	ON	OFF	ON
143	ON	OFF	OFF	OFF	ON	ON	ON	ON
145	ON	OFF	OFF	ON	OFF	OFF	OFF	ON
147	ON	OFF	OFF	ON	OFF	OFF	ON	ON
149	ON	OFF	OFF	ON	OFF	ON	OFF	ON
151	ON	OFF	OFF	ON	OFF	ON	ON	ON
153	ON	OFF	OFF	ON	ON	OFF	OFF	ON
155	ON	OFF	OFF	ON	ON	OFF	ON	ON

Table 14 (continued)

**Programming Flowcharts**

Table 14 (continued)

<b>“SA01”</b>								
<b>SPECIAL VEND VALUE</b>	<b>SAT</b>	<b>FRI</b>	<b>THUR</b>	<b>WED</b>	<b>TUE</b>	<b>MON</b>	<b>SUN</b>	<b>ON/OFF</b>
157	ON	OFF	OFF	ON	ON	ON	OFF	ON
159	ON	OFF	OFF	ON	ON	ON	ON	ON
161	ON	OFF	ON	OFF	OFF	OFF	OFF	ON
163	ON	OFF	ON	OFF	OFF	OFF	ON	ON
165	ON	OFF	ON	OFF	OFF	ON	OFF	ON
167	ON	OFF	ON	OFF	OFF	ON	ON	ON
169	ON	OFF	ON	OFF	ON	OFF	OFF	ON
171	ON	OFF	ON	OFF	ON	OFF	ON	ON
173	ON	OFF	ON	OFF	ON	ON	OFF	ON
175	ON	OFF	ON	OFF	ON	ON	ON	ON
177	ON	OFF	ON	ON	OFF	OFF	OFF	ON
179	ON	OFF	ON	ON	OFF	OFF	ON	ON
181	ON	OFF	ON	ON	OFF	ON	OFF	ON
183	ON	OFF	ON	ON	OFF	ON	ON	ON
185	ON	OFF	ON	ON	ON	OFF	OFF	ON
187	ON	OFF	ON	ON	ON	OFF	ON	ON
189	ON	OFF	ON	ON	ON	ON	OFF	ON
191	ON	OFF	ON	ON	ON	ON	ON	ON
193	ON	ON	OFF	OFF	OFF	OFF	OFF	ON
195	ON	ON	OFF	OFF	OFF	OFF	ON	ON
197	ON	ON	OFF	OFF	OFF	ON	OFF	ON
199	ON	ON	OFF	OFF	OFF	ON	ON	ON
201	ON	ON	OFF	OFF	ON	OFF	OFF	ON
203	ON	ON	OFF	OFF	ON	OFF	ON	ON
205	ON	ON	OFF	OFF	ON	ON	OFF	ON
207	ON	ON	OFF	OFF	ON	ON	ON	ON
209	ON	ON	OFF	ON	OFF	OFF	OFF	ON
211	ON	ON	OFF	ON	OFF	OFF	ON	ON
213	ON	ON	OFF	ON	OFF	ON	OFF	ON
215	ON	ON	OFF	ON	OFF	ON	ON	ON
217	ON	ON	OFF	ON	ON	OFF	OFF	ON
219	ON	ON	OFF	ON	ON	OFF	ON	ON
221	ON	ON	OFF	ON	ON	ON	OFF	ON
223	ON	ON	OFF	ON	ON	ON	ON	ON
225	ON	ON	ON	OFF	OFF	OFF	OFF	ON
227	ON	ON	ON	OFF	OFF	OFF	ON	ON
229	ON	ON	ON	OFF	OFF	ON	OFF	ON
231	ON	ON	ON	OFF	OFF	ON	ON	ON
233	ON	ON	ON	OFF	ON	OFF	OFF	ON
235	ON	ON	ON	OFF	ON	OFF	ON	ON
237	ON	ON	ON	OFF	ON	ON	OFF	ON
239	ON	ON	ON	OFF	ON	ON	ON	ON
241	ON	ON	ON	ON	OFF	OFF	OFF	ON
243	ON	ON	ON	ON	OFF	OFF	ON	ON

Table 14 (continued)

Table 14 (continued)

"SA01"								
SPECIAL VEND VALUE	SAT	FRI	THUR	WED	TUE	MON	SUN	ON/OFF
245	ON	ON	ON	ON	OFF	ON	OFF	ON
247	ON	ON	ON	ON	OFF	ON	ON	ON
249	ON	ON	ON	ON	ON	OFF	OFF	ON
251	ON	ON	ON	ON	ON	OFF	ON	ON
253	ON	ON	ON	ON	ON	ON	OFF	ON
255	ON	ON	ON	ON	ON	ON	ON	ON

Table 14

## Programming Flowcharts

### How to Program Special Vend A Start Hour “SA02”

This option allows the owner to set the hour that Special Vend A will begin, from 0-23.

1. Press the NORMAL/COLD (^) or the DELICATE/COLD (v) keypad to scroll through the programmable Special Vend A options until “SA02” appears in the display.
2. When “SA02” appears in the display, press the START (enter) keypad. The current start time (in military time) will appear in the display.

**NOTE: The hours will be displayed in military time (0-23).**

3. Press the NORMAL/COLD (^) or the DELICATE/COLD (v) keypad to increase or decrease the start hour to the desired hour.
4. Press the START (enter) keypad when the correct hour appears in the display. The next Special Vend A option, “SA03”, will appear in the display.

**NOTE: To program “SA03” (Special Vend A Start Minute), continue to next Special Vend A option. To program other options, press the DELICATE/WARM (<) keypad and refer to the appropriate section.**

### How to Exit Programming Feature

Press the DELICATE/WARM (<) keypad until the control returns to Ready Mode.

### How to Program Special Vend A Start Minute “SA03”

This option allows the owner to set the minute that Special Vend A will begin, from 0-59.

1. Press the NORMAL/COLD (^) or the DELICATE/COLD (v) keypad to scroll through the programmable Special Vend A options until “SA03” appears in the display.
2. When “SA03” appears in the display, press the START (enter) keypad. The current start minute will appear in the display.
3. Press the NORMAL/COLD (^) or the DELICATE/COLD (v) keypad to increase or decrease the start minute to the desired minute.
4. Press the START (enter) keypad when the correct minute appears in the display. The next Special Vend A option, “SA04”, will appear in the display.

**NOTE: To program “SA04” (Special Vend A Length in Hours), continue to next Special Vend A option. To program other options, press the DELICATE/WARM (<) keypad and refer to the appropriate section.**

### How to Exit Programming Feature

Press the DELICATE/WARM (<) keypad until the control returns to Ready Mode.

## How to Program Special Vend A Length in Hours “SA04”

This option allows the owner to set the length in hours for Special Vend A, from 0-24.

1. Press the NORMAL/COLD (^) or the DELICATE/COLD (v) keypad to scroll through the programmable Special Vend A options until “SA04” appears in the display.
2. When “SA04” appears in the display, press the START (enter) keypad. The current length in hours will appear in the display.
3. Press the NORMAL/COLD (^) or the DELICATE/COLD (v) keypad to increase or decrease the current length of hours to the desired number of hours.
4. Press the START (enter) keypad when the correct hour appears in the display. The next Special Vend A option, “SA05”, will appear in the display.

**NOTE: To program “SA05” (Special Vend A Start Month), continue to next Special Vend A option. To program other options, press the DELICATE/WARM (<) keypad and refer to the appropriate section.**

## How to Exit Programming Feature

Press the DELICATE/WARM (<) keypad until the control returns to Ready Mode.

## How to Program Special Vend A Start Month “SA05”

This option allows the owner to set the month that Special Vend A will begin, from 1-12.

**NOTE: If Special Vend A Start Month, Start Date, End Month, or End Date are programmed to zero (default is zero), the Special Vend A will be active every week on the days programmed in Table 14.**

1. Press the NORMAL/COLD (^) or the DELICATE/COLD (v) keypad to scroll through the programmable Special Vend A options until “SA05” appears in the display.
2. When “SA05” appears in the display, press the START (enter) keypad. The current start month will appear in the display.
3. Press the NORMAL/COLD (^) or the DELICATE/COLD (v) keypad to increase or decrease the start month to the desired month.

If “0” is selected and Special Vend A is on, Special Vend A will occur at the time and days of week selected, regardless of the month.

4. Press the START (enter) keypad when the correct month appears in the display. The next Special Vend A option, “SA06”, will appear in the display.

**NOTE: To program “SA06” (Special Vend A Start Date), continue to next Special Vend A option. To program other options, press the DELICATE/WARM (<) keypad and refer to the appropriate section.**

## How to Exit Programming Feature

Press the DELICATE/WARM (<) keypad until the control returns to Ready Mode.

## Programming Flowcharts

### How to Program Special Vend A Start Date “SA06”

This option allows the owner to set the date that Special Vend A will begin, from 1-31.

1. Press the NORMAL/COLD (^) or the DELICATE/COLD (v) keypad to scroll through the programmable Special Vend A options until “SA06” appears in the display.
2. When “SA06” appears in the display, press the START (enter) keypad. The current start date will appear in the display.
3. Press the NORMAL/COLD (^) or the DELICATE/COLD (v) keypad to increase or decrease the start date to the desired date.  
If “0” is selected and Special Vend A is on, Special Vend A will occur at the time and days of week selected, regardless of the date.
4. Press the START (enter) keypad when the correct date appears in the display. The next Special Vend A option, “SA08”, will appear in the display.

**NOTE: To program “SA08” (Special Vend A End Month), continue to next Special Vend A option. To program other options, press the DELICATE/WARM (<) keypad and refer to the appropriate section.**

### How to Exit Programming Feature

Press the DELICATE/WARM (<) keypad until the control returns to Ready Mode.

### How to Program Special Vend A End Month “SA08”

This option allows the owner to set the month that Special Vend A will end, from 1-12.

1. Press the NORMAL/COLD (^) or the DELICATE/COLD (v) keypad to scroll through the programmable Special Vend A options until “SA08” appears in the display.
2. When “SA08” appears in the display, press the START (enter) keypad. The current end month will appear in the display.
3. Press the NORMAL/COLD (^) or the DELICATE/COLD (v) keypad to increase or decrease the end month to the desired month.  
If “0” is selected and Special Vend A is on, Special Vend A will occur at the time and day of week selected, regardless of the month.
4. Press the START (enter) keypad when the correct month appears in the display. The next Special Vend A option, “SA09”, will appear in the display.

**NOTE: To program “SA09” (Special Vend A End Date), continue to next Special Vend A option. To program other options, press the DELICATE/WARM (<) keypad and refer to the appropriate section.**

### How to Exit Programming Feature

Press the DELICATE/WARM (<) keypad until the control returns to Ready Mode.

## How to Program Special Vend A End Date “SA09”

This option allows the owner to set the date that Special Vend A will end, from 1-31.

1. Press the NORMAL/COLD (^) or the DELICATE/COLD (v) keypad to scroll through the programmable Special Vend A options until “SA09” appears in the display.
2. When “SA09” appears in the display, press the START (enter) keypad. The current end date will appear in the display.
3. Press the NORMAL/COLD (^) or the DELICATE/COLD (v) keypad to increase or decrease the end date to the desired date.

If “0” is selected and Special Vend A is on, Special Vend A will occur at the time or days of week selected, regardless of the date.

4. Press the START (enter) keypad when the correct date appears in the display. The next Special Vend A option, “SA11”, will appear in the display.

**NOTE: To program “SA11” (Special Vend A Normal/Hot Vend Price), continue to next Special Vend A option. To program other options, press the DELICATE/WARM (<) keypad and refer to the appropriate section.**

## How to Exit Programming Feature

Press the DELICATE/WARM (<) keypad until the control returns to Ready Mode.

## Programming Flowcharts

### How to Program Special Vend A Normal/ Hot Vend Price “SA11”

This option allows the owner to set the vend price for a NORMAL/HOT wash in Special Vend A. The corresponding LED will be lit while programming.

1. Press the NORMAL/COLD (^) or the DELICATE/COLD (v) keypad to scroll through the programmable Special Vend A options until “SA11” appears in the display.
2. When “SA11” appears in the display, press the START (enter) keypad. There are five digits in the Special Vend A Normal/Hot Vend Price. The fifth digit will appear in the display and will flash one (1) second on and one (1) second off. Refer to *Figure 15*.

**NOTE: If the vend price is \$100.00 or more, the fifth digit is “1-6”. If the vend price is \$99.99 or less, the fifth digit is “0”.**

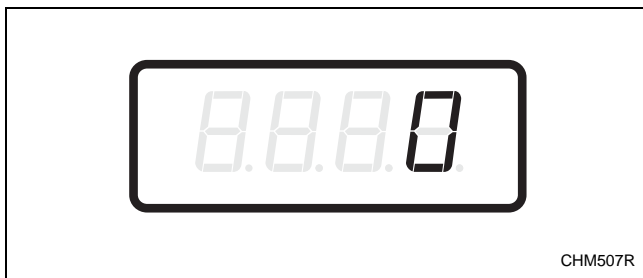

Figure 15

3. Press the NORMAL/COLD (^) or the DELICATE/COLD (v) keypad to increase or decrease the value of the fifth digit.

**NOTE: The vend price can be set from 0 to 65,535.**

4. Press the START (enter) keypad to enter the fifth digit and display remaining four digits. The active digit will flash one (1) second on and one (1) second off.

**NOTE: To go back to the current programmable Special Vend A option without changing the value of the active digit, press the DELICATE/WARM (<) keypad.**

5. Press the NORMAL/COLD (^) or the DELICATE/COLD (v) keypad to increase or decrease the value of the active digit and the START keypad to enter the value of the digit and advance to the next digit.
6. Press the START (enter) keypad with the last active digit. The next Special Vend A option, “SA12”, will appear in the display.

**NOTE: To program “SA12” (Special Vend A Normal/Warm Vend Price), continue to next Special Vend A option. To program other options, press the DELICATE/WARM (<) keypad and refer to the appropriate section.**

### How to Exit Programming Feature

Press the DELICATE/WARM (<) keypad until the control returns to Ready Mode.

## How to Program Special Vend A Normal/Warm Vend Price “SA12”

This option allows the owner to set the vend price for a NORMAL/WARM wash in Special Vend A. The corresponding LED will be lit while programming.

1. Press the NORMAL/COLD (^) or the DELICATE/COLD (v) keypad to scroll through the programmable Special Vend A options until “SA12” appears in the display.
2. When “SA12” appears in the display, press the START (enter) keypad. There are five digits in the Special Vend A Normal/Warm Vend Price. The fifth digit will appear in the display and will flash one (1) second on and one (1) second off. Refer to *Figure 16*.

**NOTE: If the vend price is \$100.00 or more, the fifth digit is “1-6”. If the vend price is \$99.99 or less, the fifth digit is “0”.**



Figure 16

3. Press the NORMAL/COLD (^) or the DELICATE/COLD (v) keypad to increase or decrease the value of the fifth digit.

**NOTE: The vend price can be set from 0 to 65,535.**

4. Press the START (enter) keypad to enter the fifth digit and display remaining four digits. The active digit will flash one (1) second on and one (1) second off.

**NOTE: To go back to the current programmable Special Vend A option without changing the value of the active digit, press the DELICATE/WARM (<) keypad.**

5. Press the NORMAL/COLD (^) or the DELICATE/COLD (v) keypad to increase or decrease the value of the active digit and the START keypad to enter the value of the digit and advance to the next digit.
6. Press the START (enter) keypad with the last active digit. The next Special Vend A option, “SA13”, will appear in the display.

**NOTE: To program “SA13” (Special Vend A Normal/cold Vend Price), continue to next Special Vend A option. To program other options, press the DELICATE/WARM (<) keypad and refer to the appropriate section.**

## How to Exit Programming Feature

Press the DELICATE/WARM (<) keypad until the control returns to Ready Mode.

## Programming Flowcharts

### How to Program Special Vend A Normal/Cold Vend Price “SA13”

This option allows the owner to set the vend price for a NORMAL/COLD wash in Special Vend A. The corresponding LED will be lit while programming.

1. Press the NORMAL/COLD (^) or the DELICATE/COLD (v) keypad to scroll through the programmable Special Vend A options until “SA13” appears in the display.
2. When “SA13” appears in the display, press the START (enter) keypad. There are five digits in the Special Vend A NORMAL/COLD Vend Price. The fifth digit will appear in the display and will flash one (1) second on and one (1) second off. Refer to *Figure 17*.

**NOTE: If the vend price is \$100.00 or more, the fifth digit is “1-6”. If the vend price is \$99.99 or less, the fifth digit is “0”.**

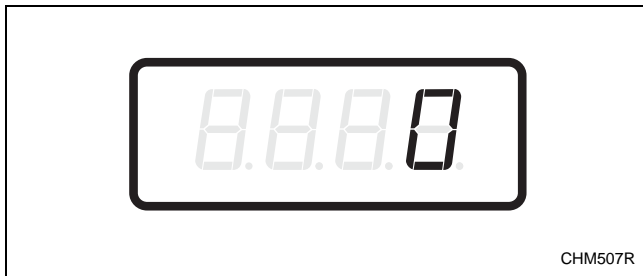

Figure 17

3. Press the NORMAL/COLD (^) or the DELICATE/COLD (v) keypad to increase or decrease the value of the fifth digit.

**NOTE: The vend price can be set from 0 to 65,535.**

4. Press the START (enter) keypad to enter the fifth digit and display remaining four digits. The active digit will flash one (1) second on and one (1) second off.

**NOTE: To go back to the current programmable Special Vend A option without changing the value of the active digit, press the DELICATE/WARM (<) keypad.**

5. Press the NORMAL/COLD (^) or the DELICATE/COLD (v) keypad to increase or decrease the value of the active digit and the START keypad to enter the value of the digit and advance to the next digit.
6. Press the START (enter) keypad with the last active digit. The next Special Vend A option, “SA14”, will appear in the display.

**NOTE: To program “SA14” (Special Vend A Heavy/Hot Vend Price), continue to next Special Vend A option. To program other options, press the DELICATE/WARM (<) keypad and refer to the appropriate section.**

### How to Exit Programming Feature

Press the DELICATE/WARM (<) keypad until the control returns to Ready Mode.

## How to Program Special Vend A Heavy/ Hot Vend Price “SA14”

This option allows the owner to set the vend price for a HEAVY/HOT wash in Special Vend A. The corresponding LED will be lit while programming.

1. Press the NORMAL/COLD (^) or the DELICATE/COLD (v) keypad to scroll through the programmable Special Vend A options until “SA14” appears in the display.
2. When “SA14” appears in the display, press the START (enter) keypad. There are five digits in the Special Vend A Heavy/Hot Vend Price. The fifth digit will appear in the display and will flash one (1) second on and one (1) second off. Refer to *Figure 18*.

**NOTE: If the vend price is \$100.00 or more, the fifth digit is “1-6”. If the vend price is \$99.99 or less, the fifth digit is “0”.**

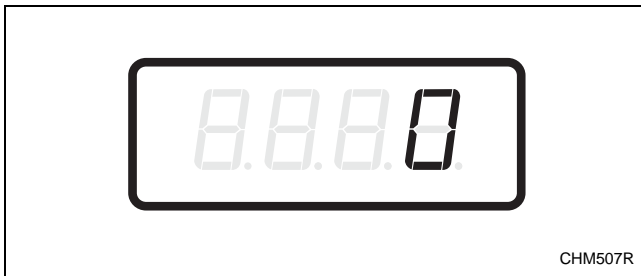

Figure 18

3. Press the NORMAL/COLD (^) or the DELICATE/COLD (v) keypad to increase or decrease the value of the fifth digit.

**NOTE: The vend price can be set from 0 to 65,535.**

4. Press the START (enter) keypad to enter the fifth digit and display remaining four digits. The active digit will flash one (1) second on and one (1) second off.

**NOTE: To go back to the current programmable Special Vend A option without changing the value of the active digit, press the DELICATE/WARM (<) keypad.**

5. Press the NORMAL/COLD (^) or the DELICATE/COLD (v) keypad to increase or decrease the value of the active digit and the START keypad to enter the value of the digit and advance to the next digit.
6. Press the START (enter) keypad with the last active digit. The next Special Vend A option, “SA15”, will appear in the display.

**NOTE: To program “SA15” (Special Vend A Delicate/Warm Vend Price), continue to next Special Vend A option. To program other options, press the DELICATE/WARM (<) keypad and refer to the appropriate section.**

## How to Exit Programming Feature

Press the DELICATE/WARM (<) keypad until the control returns to Ready Mode.

## Programming Flowcharts

### How to Program Special Vend A Delicate/Warm Vend Price “SA15”

This option allows the owner to set the vend price for a DELICATE/WARM wash in Special Vend A. The corresponding LED will be lit while programming.

1. Press the NORMAL/COLD (^) or the DELICATE/COLD (v) keypad to scroll through the programmable Special Vend A options until “SA15” appears in the display.
2. When “SA15” appears in the display, press the START (enter) keypad. There are five digits in the Special Vend A Delicate/Warm Vend Price. The fifth digit will appear in the display and will flash one (1) second on and one (1) second off. Refer to *Figure 19*.

**NOTE: If the vend price is \$100.00 or more, the fifth digit is “1-6”. If the vend price is \$99.99 or less, the fifth digit is “0”.**

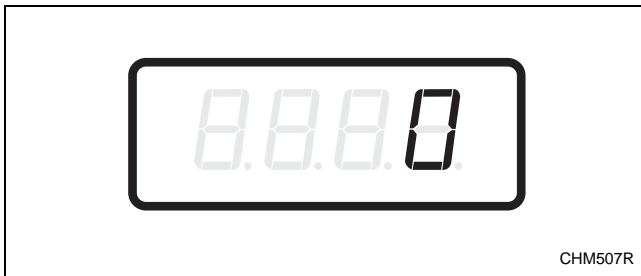

Figure 19

3. Press the NORMAL/COLD (^) or the DELICATE/COLD (v) keypad to increase or decrease the value of the fifth digit.

**NOTE: The vend price can be set from 0 to 65,535.**

4. Press the START (enter) keypad to enter the fifth digit and display remaining four digits. The active digit will flash one (1) second on and one (1) second off.

**NOTE: To go back to the current programmable Special Vend A option without changing the value of the active digit, press the DELICATE/WARM (<) keypad.**

5. Press the NORMAL/COLD (^) or the DELICATE/COLD (v) keypad to increase or decrease the value of the active digit and the START keypad to enter the value of the digit and advance to the next digit.
6. Press the START (enter) keypad with the last active digit. The next Special Vend A option, “SA16”, will appear in the display.

**NOTE: To program “SA16” (Special Vend A Delicate/Cold Vend Price), continue to next Special Vend A option. To program other options, press the DELICATE/WARM (<) keypad and refer to the appropriate section.**

### How to Exit Programming Feature

Press the DELICATE/WARM (<) keypad until the control returns to Ready Mode.

## How to Program Special Vend A Delicate/Cold Vend Price “SA16”

This option allows the owner to set the vend price for a DELICATE/COLD wash in Special Vend A. The corresponding LED will be lit while programming.

1. Press the NORMAL/COLD (^) or the DELICATE/COLD (v) keypad to scroll through the programmable Special Vend A options until “SA16” appears in the display.
2. When “SA16” appears in the display, press the START (enter) keypad. There are five digits in the Special Vend A Delicate/Cold Vend Price. The fifth digit will appear in the display and will flash one (1) second on and one (1) second off. Refer to *Figure 20*.

**NOTE: If the vend price is \$100.00 or more, the fifth digit is “1-6”. If the vend price is \$99.99 or less, the fifth digit is “0”.**

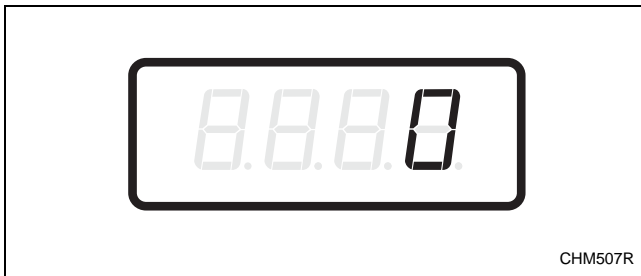

Figure 20

3. Press the NORMAL/COLD (^) or the DELICATE/COLD (v) keypad to increase or decrease the value of the fifth digit.

**NOTE: The vend price can be set from 0 to 65,535.**

4. Press the START (enter) keypad to enter the fifth digit and display remaining four digits. The active digit will flash one (1) second on and one (1) second off.

**NOTE: To go back to the current programmable Special Vend A option without changing the value of the active digit, press the DELICATE/WARM (<) keypad.**

5. Press the NORMAL/COLD (^) or the DELICATE/COLD (v) keypad to increase or decrease the value of the active digit and the START keypad to enter the value of the digit and advance to the next digit.
6. Press the START (enter) keypad with the last active digit. The next Special Vend A option, “SA17”, will appear in the display.

**NOTE: To program “SA17” (Special Vend A Quick/Hot Vend Price), continue to next Special Vend A option. To program other options, press the DELICATE/WARM (<) keypad and refer to the appropriate section.**

## How to Exit Programming Feature

Press the DELICATE/WARM (<) keypad until the control returns to Ready Mode.

## Programming Flowcharts

### How to Program Special Vend A Quick/Hot Vend Price “SA17”

This option allows the owner to set the vend price for a QUICK/HOT wash in Special Vend A. The corresponding LED will be lit while programming.

1. Press the NORMAL/COLD (^) or the DELICATE/COLD (v) keypad to scroll through the programmable Special Vend A options until “SA17” appears in the display.
2. When “SA17” appears in the display, press the START (enter) keypad. There are five digits in the Special Vend A Quick/Hot Vend Price. The fifth digit will appear in the display and will flash one (1) second on and one (1) second off. Refer to *Figure 21*.

**NOTE: If the vend price is \$100.00 or more, the fifth digit is “1-6”. If the vend price is \$99.99 or less, the fifth digit is “0”.**

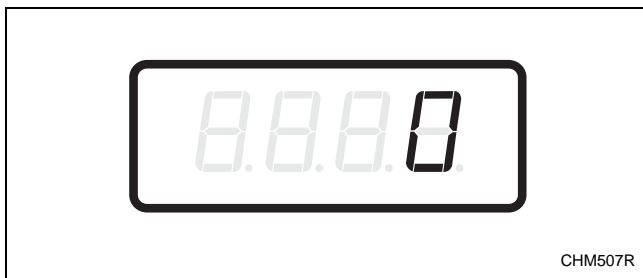

Figure 21

3. Press the NORMAL/COLD (^) or the DELICATE/COLD (v) keypad to increase or decrease the value of the fifth digit.

**NOTE: The vend price can be set from 0 to 65,535.**

4. Press the START (enter) keypad to enter the fifth digit and display remaining four digits. The active digit will flash one (1) second on and one (1) second off.

**NOTE: To go back to the current programmable Special Vend A option without changing the value of the active digit, press the DELICATE/WARM (<) keypad.**

5. Press the NORMAL/COLD (^) or the DELICATE/COLD (v) keypad to increase or decrease the value of the active digit and the START keypad to enter the value of the digit and advance to the next digit.
6. Press the START (enter) keypad with the last active digit. The next Special Vend A option, “SA18”, will appear in the display.

**NOTE: To program “SA18” (Special Vend A Quick/Warm Vend Price), continue to next Special Vend A option. To program other options, press the DELICATE/WARM (<) keypad and refer to the appropriate section.**

### How to Exit Programming Feature

Press the DELICATE/WARM (<) keypad until the control returns to Ready Mode.

## How to Program Special Vend A Quick/Warm Vend Price “SA18”

This option allows the owner to set the vend price for a QUICK/WARM wash in Special Vend A. The corresponding LED will be lit while programming.

1. Press the NORMAL/COLD (^) or the DELICATE/COLD (v) keypad to scroll through the programmable Special Vend A options until “SA18” appears in the display.
2. When “SA18” appears in the display, press the START (enter) keypad. There are five digits in the Special Vend A Quick/Warm Vend Price. The fifth digit will appear in the display and will flash one (1) second on and one (1) second off. Refer to *Figure 22*.

**NOTE: If the vend price is \$100.00 or more, the fifth digit is “1-6”. If the vend price is \$99.99 or less, the fifth digit is “0”.**



Figure 22

3. Press the NORMAL/COLD (^) or the DELICATE/COLD (v) keypad to increase or decrease the value of the fifth digit.

**NOTE: The vend price can be set from 0 to 65,535.**

4. Press the START (enter) keypad to enter the fifth digit and display remaining four digits. The active digit will flash one (1) second on and one (1) second off.

**NOTE: To go back to the current programmable Special Vend A option without changing the value of the active digit, press the DELICATE/WARM (<) keypad.**

5. Press the NORMAL/COLD (^) or the DELICATE/COLD (v) keypad to increase or decrease the value of the active digit and the START keypad to enter the value of the digit and advance to the next digit.
6. Press the START (enter) keypad with the last active digit. The next Special Vend A option, “SA19”, will appear in the display.

**NOTE: To program “SA19” (Special Vend A Quick/Cold Vend Price), continue to next Special Vend A option. To program other options, press the DELICATE/WARM (<) keypad and refer to the appropriate section.**

## How to Exit Programming Feature

Press the DELICATE/WARM (<) keypad until the control returns to Ready Mode.

## Programming Flowcharts

### How to Program Special Vend A Quick/ Cold Vend Price “SA19”

This option allows the owner to set the vend price for a QUICK/COLD wash in Special Vend A. The corresponding LED will be lit while programming.

1. Press the NORMAL/COLD (^) or the DELICATE/COLD (v) keypad to scroll through the programmable Special Vend A options until “SA19” appears in the display.
2. When “SA19” appears in the display, press the START (enter) keypad. There are five digits in the Special Vend A Quick/Cold Vend Price. The fifth digit will appear in the display and will flash one (1) second on and one (1) second off. Refer to *Figure 23*.

**NOTE: If the vend price is \$100.00 or more, the fifth digit is “1-6”. If the vend price is \$99.99 or less, the fifth digit is “0”.**

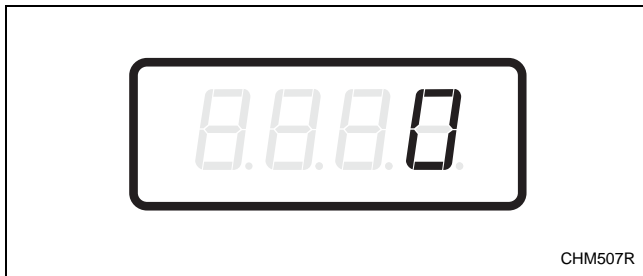

Figure 23

3. Press the NORMAL/COLD (^) or the DELICATE/COLD (v) keypad to increase or decrease the value of the fifth digit.

**NOTE: The vend price can be set from 0 to 65,535.**

4. Press the START (enter) keypad to enter the fifth digit and display remaining four digits. The active digit will flash one (1) second on and one (1) second off.

**NOTE: To go back to the current programmable Special Vend A option without changing the value of the active digit, press the DELICATE/WARM (<) keypad.**

5. Press the NORMAL/COLD (^) or the DELICATE/COLD (v) keypad to increase or decrease the value of the active digit and the START keypad to enter the value of the digit and advance to the next digit.
6. Press the START (enter) keypad with the last active digit. The next Special Vend A option, “SA20”, will appear in the display.

**NOTE: To program “SA20” (Special Vend A Wash Agitate Step Added Minutes), continue to next Special Vend A option. To program other options, press the DELICATE/WARM (<) keypad and refer to the appropriate section.**

### How to Exit Programming Feature

Press the DELICATE/WARM (<) keypad until the control returns to Ready Mode.

### How to Program Special Vend A Wash Agitate Step Added Minutes “SA20”

This option allows the owner to add time to the wash agitate part of the cycle in Special Vend A.

1. Press the NORMAL/COLD (^) or the DELICATE/COLD (v) keypad to scroll through the programmable Special Vend A options until “SA20” appears in the display.
2. When “SA20” appears in the display, press the START (enter) keypad.
3. Press the NORMAL/COLD (^) or the DELICATE/COLD (v) keypad to increase or decrease the number of minutes displayed to the desired number of added minutes.

**NOTE: The Special Vend A Added Wash Agitate Time can be set from zero “0” to 15 minutes.**

4. Press the START (enter) keypad when the correct number of minutes appears in the display. The next Special Vend A option, “SA21”, will appear in the display.

**NOTE: To program “SA21” (Special Vend A Wash Agitate Step Subtracted Minutes), continue to next Special Vend A option. To program other options, press the DELICATE/WARM (<) keypad and refer to the appropriate section.**

### How to Exit Programming Feature

Press the DELICATE/WARM (<) keypad until the control returns to Ready Mode.

### How to Program Special Vend A Wash Agitate Step Subtracted Minutes “SA21”

This option allows the owner to subtract time from the wash agitate part of the cycle in Special Vend A.

1. Press the NORMAL/COLD (^) or the DELICATE/COLD (v) keypad to scroll through the programmable Special Vend A options until “SA21” appears in the display.
2. When “SA21” appears in the display, press the START (enter) keypad.
3. Press the NORMAL/COLD (^) or the DELICATE/COLD (v) keypad to increase or decrease the number of minutes displayed to the desired number of subtracted minutes.

**NOTE: The Special Vend A Subtracted Wash Agitate Time can be set from zero “0” to 15 minutes.**

4. Press the START (enter) keypad when the correct number of minutes appears in the display. The next Special Vend A option, “SA01”, will appear in the display.

**NOTE: To program “FLo” (Low Water Level), press the DELICATE/WARM (<) keypad and refer to *option 37*. To program other options refer to the appropriate section.**

### How to Exit Programming Feature

Press the DELICATE/WARM (<) keypad until the control returns to Ready Mode.

### 37. Low Water Level “FLo”

This option allows the owner to program the low water level during fill and tumble of all cycles.

#### How to Program Low Water Level

1. Control must be in Manual Mode. Refer to *Entering the Manual Mode*.
2. Press the NORMAL/COLD (^) or the DELICATE/COLD (v) keypad until “Prog” appears in the display. Press the START (enter) keypad and “AtS1” will appear in the display.
3. Press the NORMAL/COLD (^) or the DELICATE/COLD (v) keypad to scroll through the programmable options until “FLo” appears in the display.
4. When “FLo” appears in the display, press the START (enter) keypad. A number will appear in the display. This number corresponds to the current low water level during tumble and fill of all cycles.
5. Press the NORMAL/COLD (^) or the DELICATE/COLD (v) keypad to increase or decrease the current water level to the desired water level.

**NOTE: The Low Water Level value can be set from 1 to 10. Default Low Water Level value is 3.**

6. Press the START (enter) keypad when the correct number appears in the display. The next option, “FnEd”, will appear in the display.

**NOTE: To program “FnEd” (Medium Water Level), refer to *option 38*. To program other options, refer to the appropriate section.**

#### How to Exit Programming Feature

Press the DELICATE/WARM (<) keypad until the control returns to Ready Mode.

### 38. Medium Water Level “FnEd”

This option allows the owner to program the medium water level during fill and tumble of all cycles.

#### How to Program Medium Water Level

1. Control must be in Manual Mode. Refer to *Entering the Manual Mode*.
2. Press the NORMAL/COLD (^) or the DELICATE/COLD (v) keypad until “Prog” appears in the display. Press the START (enter) keypad and “AtS1” will appear in the display.
3. Press the NORMAL/COLD (^) or the DELICATE/COLD (v) keypad to scroll through the programmable options until “FnEd” appears in the display.
4. When “FnEd” appears in the display, press the START (enter) keypad. A number will appear in the display. This number corresponds to the current medium water level during tumble and fill of all cycles.
5. Press the NORMAL/COLD (^) or the DELICATE/COLD (v) keypad to increase or decrease the current water level to the desired water level.

**NOTE: The Medium Water Level value can be set from 11 to 20. Default Medium Water Level value is 15.**

6. Press the START (enter) keypad when the correct number appears in the display. The next option, “FHI”, will appear in the display.

**NOTE: To program “FHI” (High Water Level), refer to *option 39*. To program other options, refer to the appropriate section.**

#### How to Exit Programming Feature

Press the DELICATE/WARM (<) keypad until the control returns to Ready Mode.

### 39. High Water Level “FHI”

This option allows the owner to program the high water level during fill and tumble of all cycles.

#### How to Program High Water Level

1. Control must be in Manual Mode. Refer to *Entering the Manual Mode*.
2. Press the NORMAL/COLD (∧) or the DELICATE/COLD (∨) keypad until “Prog” appears in the display. Press the START (enter) keypad and “AtS1” will appear in the display.
3. Press the NORMAL/COLD (∧) or the DELICATE/COLD (∨) keypad to scroll through the programmable options until “FHI” appears in the display.
4. When “FHI” appears in the display, press the START (enter) keypad. A number will appear in the display. This number corresponds to the current high water level during tumble and fill of all cycles.
5. Press the NORMAL/COLD (∧) or the DELICATE/COLD (∨) keypad to increase or decrease the current water level to the desired water level.

**NOTE: The High Water Level value can be set from 21 to 30. Default High Water Level setting is 27.**

6. Press the START (enter) keypad when the correct number appears in the display. The next option, “ALd-”, will appear in the display.

**NOTE: To program “ALd-” (Auto-Water Leak Detection), refer to *option 40*. To program other options, refer to the appropriate section.**

#### How to Exit Programming Feature

Press the DELICATE/WARM (<) keypad until the control returns to Ready Mode.

### 40. Auto-Water Leak Detection “ALd-”

This option allows the owner to set the time and frequency that the control automatically checks the water level. The owner programs which day(s) of the week and hour of day(s) they want this test to occur. The owner may also program this test to occur after XX number of machine cycles have been completed since the last time the test was run. In order for this auto-water leak detection test to occur, the machine’s door must be closed.

#### How to Program the Auto-Water Leak Detection

1. Control must be in Manual Mode. Refer to *Entering the Manual Mode*.
2. Press the NORMAL/COLD (∧) or the DELICATE/COLD (∨) keypad until “Prog” appears in the display. Press the START (enter) keypad and “AtS1” will appear in the display.
3. Press the NORMAL/COLD (∧) or the DELICATE/COLD (∨) keypad to scroll through the programmable options until “ALd-” appears in the display. Press the START keypad and “ALd1” will appear in the display.
4. Press the NORMAL/COLD (∧) or the DELICATE/COLD (∨) keypad to scroll through the programmable options. Refer to *Table 15*.

“ALd1”	Auto-Water Leak Detection (“oFF”* or “0” through “127” cycles [“On”] – Number of completed cycles after which this test will occur)
“ALd2”	Auto-Water Leak Detection Hour (“0”* – “23” – Hour of the day this test will occur)
“ALd3”	Auto-Water Leak Detection Day of Week (“0” – “127”* – Refer to <i>Table 7</i> )

\*Factory Default Setting

Table 15

## Programming Flowcharts

5. When the desired option appears in the display, press the START (enter) keypad. The current value will appear in the display.
6. Press the NORMAL/COLD (^) or the DELICATE/COLD (v) keypad to enable during cycles, disable, increase or decrease the hours, or day.

**NOTE: The hours will be displayed in military time. For day of week, Sunday is considered day one (1), Monday is day two (2) and so on. Refer to Table 7.**

7. Press the START (enter) keypad when the correct value appears in the display. The next option “AtS1”, will appear in the display.

**NOTE: To program “AtS1” (Normal/Hot Vend Price), refer to *option 1*. To program other options, refer to the appropriate section.**

### How to Exit Programming Feature

Press the DELICATE/WARM (<) keypad until the control returns to Ready Mode.

# Collecting Audit Information

This feature allows the owner to retrieve audit information stored in the washer-extractor by pressing a sequence of pads on the control. For an explanation of the audit options available, refer to *Table 16*.

## How to Enter Audit Feature

There are two methods the owner can use to enter the Audit Feature.

### Entering the Audit Feature by Manual Mode

1. Control must be in Manual Mode to start. Refer to *Entering the Manual Mode*.
2. Press the NORMAL/COLD (^) or the DELICATE/COLD (v) keypad until "AUdt" appears.
3. Press the START (enter) keypad. "CyC" will appear.

### Entering the Audit Feature with the Coin Vault Open

1. Open coin vault. Make sure top cover is closed.
2. Press the START (enter) keypad.

### How to Read Audit Data

1. Use the NORMAL/COLD (^) or the DELICATE/COLD (v) keypad to scroll through various options until the desired option is shown in the display. Refer to the Audit Options List, *Table 16*, for an explanation of the audit options available.

Audit Options List		
#	Display	Description
1	"CyC"	Total # of machine cycles
2	"rCyC"	Total # of rapid advanced cycles
3	"Coi1"	Total # of coins #1
4	"Coi2"	Total # of coins #2
5	"PLSE"	Total # of Start Pulses

Table 16

2. Once the desired option appears in the display, press the START (enter) keypad **once** to start the audit count. At this point, the display will show the first four-digit segment of the audit value. If the audit count is 10,000 or higher, press the START (enter) keypad again to view the last four digits of the number.

**NOTE:** The display can show up to 4 digits at one time. Audit counts 10,000 or higher are separated into two 4-digit segments. Each time the START (enter) keypad is pressed in step 2, the display will show the next 4-digit segment in the audit value. If the value is 9,999 or less, only one 4-digit segment will be shown.

**For Example:** In the Total Number of Coins #1 option with "Coi1" shown in the display, the audit has counted 10,009 coins. Pressing the START (enter) keypad one time will show " \_ \_ \_ 1" to represent ten thousand. Pressing the START (enter) keypad a second time will display "0009" meaning nine. The total equals "00010009" or 10,009.

3. Press the START (enter) keypad again. The control will go to the next audit option in the Audit Options List.
4. To select other audit options, repeat steps 1 – 4.

### How to Exit Audit Feature

Press the DELICATE/WARM (<) keypad.

**NOTE:** To exit Audit Feature when using Coin Vault Open method, owner must close coin vault.

# Manual Reset

This feature allows the owner to reset the washer-extractor control's programming data to the factory default settings by pressing a sequence of pads on the control. For an explanation of the Factory Default Settings, refer to *Table 1*.

## How to Enter Manual Reset

1. Control must be in Manual Mode to start.  
Refer to *Entering the Manual Mode*.
2. Press the NORMAL/COLD (^) or the DELICATE/COLD (v) keypad until "rSEt" appears.
3. Press the START (enter) keypad. The control will be blank until the programming is complete. Once the program has been reset, the control will display the next Manual Mode option, "diAg".

# Production Test Cycle

## To Enter Production Test Cycle

1. Be certain control is in Ready Mode and top cover or coin vault is open.
2. While pressing and holding the NORMAL/ COLD keypad with one hand, press the QUICK/ HOT keypad with the other hand.
3. When the control enters the Production Test Cycle, it will first display “S xx” with the “xx” showing the software version of the front end control.
4. The control will advance through the sequence of test steps whenever any key is pressed. Refer to *Table 17* for all tests in the Production Test Cycle.

## To Exit Production Test Cycle

To exit a test step, power down the machine.

**Production Test Cycle**

<b>Production Test Cycle Quick Reference Chart</b>		
<b>Display</b>	<b>Test Cycle Step</b>	<b>Comments</b>
“S xx”	FEC Control Software Version	xx is the software version number.
“o xx”	Output Board Software Version	xx is the software version number.
“Ct25”	Control Type	2.5 is the Control type.
“COIn”	Control Type	Coin
“USA”	Control Type	Domestic
“drAn”	Drain Type	Gravity drain
“tEnP”	Temp Sensor	Step skipped if not model with heat.
“HEAt”	Heater	Step skipped if not heater-equipped.
“L dC”	Door Lock Type	“L dC” for 24 VDC lock.
“droP” or “drCL”	Door Status	Door open or closed.
“drUL” or “drLo”	Door Lock Status	Door will lock.
“8.8.8.8.” + all LEDs	Display Test	All display elements are lit.
“PAxx” where xx = 1-3, 5-11	Keypad Test step	Advance after all keypads are pressed.
“A xx”	Top Cover Switch Test	xx is either “CL” for closed or “oP” for open.
“U xx”	Coin Vault Switch Test	xx is either “CL” for closed or “oP” for open.
“CxCx”	Coin Drop Test	1st x is number of Coin Drop #1 coins. 2nd x is number of Coin Drop #2 coins.
“Cxxx”	Machine Type/Size	
“HFIL”	Hot Fill to Low Level	All water outputs turned off when Low Level reached.
“CFIL”	Cold Fill to Low Level	All water outputs turned off when Low Level reached.
“bFIL”	Warm Fill to Low Level	All water outputs turned off when Low Level reached.
“bFIH”	Warm Fill to High Level	All water outputs turned off when High Level reached.
“S1” for supply or “C2Co” for compartment	Supply #1 or Compartment #2 Cold Fill	
“S2” for supply or “C2Ho” for compartment	Supply #2 or Compartment #2 Hot Fill	
“S3” for supply or “C3Co” for compartment	Supply #3 or Compartment #3 Cold Fill	
“S4” for supply or “C4Ho” for compartment	Supply #4 or Compartment #4 Hot Fill	
“xxxF” degrees F or “xxxC” degrees C depending on the Fahrenheit/Celsius programming parameter	Heat water to 110°F or display temperature	xxx is degree temperature. This step skipped if not model with heat. Heater turned off when temperature reached.

Table 17 (continued)

Table 17 (continued)

Production Test Cycle Quick Reference Chart		
Display	Test Mode	Comments
“LoAg”	Reduced Wash Speed Forward with no agitation action	This step skipped on 2 Speed Models.
“Ag”	Wash Speed Forward with no agitation action	
“rAg”	Wash Speed Reverse with no agitation action	
“drAl”	Drain Distribution Speed	
“PUrg”	Factory Valve Purge	
“SP 1”	Extract Speed #1 “very low”	This step skipped on 2 Speed Models.
“SP 2”	Extract Speed #2 “low”	This step skipped on 2 Speed Models.
“SP 3”	Extract Speed #3 “medium”	This step skipped on 2 Speed Models.
“SP 4” (VFD Models) or “SPIn” (2 Speed Models)	Extract Speed #4 “high”	This step skipped on F-Speed Models.
“SP 5”	Extract Speed #5 “very high”	This step skipped on 2 Speed and F-Speed Models.
“Prdn”	End of test	Turn Power off

Table 17

# Error Codes

Following is a list of possible error codes for an electronic control. Errors beginning with “EI” refer to external device Infra-red communication errors. Errors beginning with “EC” refer to card reader errors. All other errors refer to machine errors.

<b>Display</b>	<b>Description</b>	<b>Cause/ Corrective Action</b>
EI01	Transmission Failure	Communication failure. Re-aim external device and try again.
EI02	Time-out Error	Communication failure. Re-aim external device and try again.
EI03	Invalid Command Code	Communication successful, but the command was not valid for this machine type, or the control could not perform the command in its current mode of operation. Ensure data is for current machine type and control is in correct mode.
EI04	Expecting Upload Request	Communication failure. Re-aim external device and try again.
EI05	Invalid or Out-of-Range Data	The value in at least one of the programming options is invalid or out of range. Recheck the programming option’s value and try again.
EI09	CRC-16 Error	Communication failure. Re-aim external device and try again.
EI0A	Framing Error	Communication error. Re-aim external device and try again.
EI0C	Time-out Exceeded	Communication error. Re-aim external device and try again.
EI0E	Encryption Error	Communication error. Re-aim external device and try again. If the problem persists, check that the security code is correct.
EI0F	Infra-red Disabled	Communication failure or infra-red is disabled. Manually enable infra-red on control or re-aim external device and try again.
EC02	Time-out Error	Communication failure. Try card again.
EC03	Invalid Command Code	Communication successful, but the command was not valid for this machine type, or the control could not perform the command in its current mode of operation. Ensure data is for current machine type and control is in correct mode.
EC05	Invalid or Out-of-Range Data	The value in at least one of the programming options is invalid or out of range. Recheck the programming option’s value and try again.

Table 18 (continued)

Table 18 (continued)

<b>Display</b>	<b>Description</b>	<b>Cause/ Corrective Action</b>
EC11	No Card Reader Initialization	Communication is valid, but there is no card reader initialization. Power down, power up and try again.
EC18	No Communication	Card reader is initialized, communication lost. Power down, power up and try again. If error persists, replace control or card reader.
EC19	No Card Reader Communication	Communication failure. Power down, power up and try again. If error persists, replace control or card reader.
E FL	Fill Error	Programmed water level not reached within 10 minutes (or other programmed length of time) in any fill agitate cycle. End cycle. Power down machine to clear.
E SP	SPI Communications Error	Front End control cannot communicate with output board. Power down the machine, power up and try again.
E dL	Door Lock Error	Door does not lock immediately upon closing (open and reclose door) or doesn't unlock 5 seconds after cycle completion. Power down machine and retry.
E do	Door Open Error	Control detects door open. Caused by pulling on door while locked or about to lock. Correct inoperative door locking system. End cycle. Power down machine to clear.
E Ub	Unbalance Error	Unable to balance load. Redistribute load and run cycle.
door	Door Open Indicator	Door is not closed in Start Mode. If door is closed, check for improper wiring or faulty door switch.
Err	Coin Error	Invalid coin pulse or inoperative coin sensor. Check coin drop area and remove obstructions. If error persists, tampering may have occurred. Evaluate security procedures.
E dr	Drain Alarm Error	Machine not drained within 15 minutes (or other programmed length of time) in any drain step. End cycle. Power down machine to clear.
E Ht	Heat Alarm Error	Programmed heat alarm time of 120 minutes or other programmed length of time is exceeded. Turns off heater output for remainder of cycle.
E oP	Open Temperature Sensor Error	Control senses temperature less than 0°F (-18°C) in machine equipped with temperature sensor. Heater and thermistor related operations are disabled.
E SH	Shorted Temperature Sensor Error	Control senses temperature greater than 220°F (104°C) in machine equipped with temperature sensor. Heater and thermistor related operations are disabled for remainder of cycle.
E ro	Rotation Sensor Error	Invalid signal received from Rotation Sensor. Control will activate coast times to complete cycle.

Table 18 (continued)

**Error Codes**

Table 18 (continued)

<b>Display</b>	<b>Description</b>	<b>Cause/ Corrective Action</b>
E FS	Frame Balance Switch Error	Control detects Frame Balance Switch open. End cycle.
E db	Drive Balance Switch Error	Control detects VFD Balance Switch input closed at start of drain step. End cycle. Power down machine to clear.
E Ld	Water Leak Detection Error	If control senses a drop in water level during diagnostic testing. Power down machine to clear. If control shows error after door is open (when cycle is completed) for one minute or after test has been completed, lights the right-most decimal point* on the display and the error information will be logged in audit data.
E Sd	Slow Drain Error	If control shows error after door is open (when cycle is completed) for one minute, lights the right-most decimal point* on the display and the error information will be logged in audit data.

\*To clear the decimal point on display, press the START (enter) keypad 3 times in succession (within 5 seconds).

Table 18

# Rapid Advance Feature

The Rapid Advance feature allows the owner to quickly advance through active cycles or advance into a cycle from the ready mode.

## How to Enter Rapid Advance

1. If control is in Ready Mode, control must be put into Manual Mode. Refer to *Entering the Manual Mode*.
2. Press the NORMAL/COLD (^) or the DELICATE/COLD (v) keypad until “rAPd” appears in the display.
3. Press the START (enter) keypad. The display will show cycle time and the START (enter) keypad LED will flash.
4. Press the START (enter) keypad to start cycle.

**NOTE: Door must be closed to start cycle.**

## How to Enter Rapid Advance During an Active Cycle

1. Be certain top cover is open and coin vault switch is closed.
2. While pressing and holding the HEAVY/HOT keypad with one hand, press the NORMAL/HOT keypad with the other hand.
3. Press the NORMAL/COLD (^) or the DELICATE/COLD (v) keypad until “rAPd” appears in the display.
4. Press START (enter) to activate Rapid Advance cycle.

## How to Use Rapid Advance

Control may be in an active cycle or in the Ready Mode to use the Rapid Advance feature.

While in the Rapid Advance Mode, pressing the START (enter) keypad will advance the washer-extractor to the next cycle step. The cycle indicator lights will tell which cycle step the washer-extractor is in.

**For Example:** If the washer is in the first Fill cycle step, pressing the START (enter) keypad will advance the washer into the Agitate cycle step.

Continue pressing the START (enter) keypad until the cycle is completed.

## How to Exit Rapid Advance Feature

1. Advance through the cycles until reaching the Ready Mode.

**NOTE: The Rapid Advance option must be turned on for Rapid Advance to work. Refer to *option 22* in *Programming Control*.**

# Clear Vend Feature

The Clear Vend feature allows the owner to clear a control which is in the middle of satisfying a vend price, and set it back to the Ready Mode.

## How to Clear Vend

1. Open the top cover. Refer to *Opening the Top Cover*.
2. While pressing and holding the HEAVY/HOT keypad with one hand, press the NORMAL/WARM keypad with the other hand. The control will reset to Ready Mode.

# Power Fail Recovery

The Power Fail Recovery feature allows the cycle status to be saved in memory in the event of a power failure.

If the power failure lasted less than 2 minutes, the cycle will resume without requiring the user to press the START (enter) keypad to restart.

If the power failure lasted longer than 2 minutes, the START (enter) keypad will flash until it is pressed and the cycle will restart from the point it left off.

# Communications Mode

## Infra-red Communications

The Infra-red Communications feature allows the control to communicate with an external device. The control can be programmed and have its data read without using the keypad. It may also be used to start and stop various diagnostic tests.

### How to Begin Communications with An External Device

The control will go blank and the display will show “-C-” until the communication is complete. If an error occurs that terminates communication, the display will show “E1XX” (“XX” represents the error code).

**NOTE: The Infra-red Communications option must be turned on. Refer to *option 15* in *Programming Control*.**

## Card Reader Communications (Card Models Only)

The Card Reader Communications feature allows the control to communicate with the card reader. The control can be programmed for a limited number of options and have its data read without using the keypad.

# Default Cycles

Cycle Chart									
Cycle Stops	Normal/ Hot	Normal/ Warm	Normal/ Cold	Heavy/ Hot	Delicate/ Warm	Delicate/ Cold	Quick/ Hot	Quick/ Warm	Quick/ Cold
Cycle reference (display in Program Mode)	CYC1	CYC2	CYC3	CYC4	CYC5	CYC6	CYC7	CYC8	CYC9
Agitation type	18/3/18 Normal	18/3/18 Normal	18/3/18 Normal	18/3/18 Normal	3/12/3 Gentle	3/12/3 Gentle	18/3/18 Normal	18/3/18 Normal	18/3/18 Normal
Wash 1 (ON/OFF)	OFF	OFF	OFF	ON	OFF	OFF	OFF	OFF	OFF
Time for agitation (min.)	2	2	2	2	4	4	2	2	2
Fill Temperature	Warm	Warm	Cold	Warm	Warm	Cold	Cold	Cold	Cold
Fill Level	High	High	High	Low	High	High	Low	Low	Low
Supply	C1 (S1)	C1 (S1)	C1 (S1)	C1 (S1)	C1 (S1)	C1 (S1)	C1 (S1)	C1 (S1)	C1 (S1)
Heat (if enabled)	2	2	2	2	2	2	2	2	2
Drain	Yes	Yes	Yes	Yes	Yes	Yes	Yes	Yes	Yes
Spin (min.)	0	0	0	0	0	0	0	0	0
Wash 2 (ON/OFF)	ON	ON	ON	ON	ON	ON	ON	ON	ON
Time for agitation (min.)	6	6	6	6	6	6	4	4	4
Fill Temperature	Hot	Warm	Cold	Hot	Warm	Cold	Hot	Warm	Cold
Fill Level	Low	Low	Low	Low	Low	Low	Low	Low	Low
Supply	C1, C2, C3 (S1, S2)	C1, C2, C3 (S1, S2)	C1, C2, C3 (S1, S2)	C1, C2, C3 (S1, S2)	C1, C2, C3 (S1, S2)	C1, C2, C3 (S1, S2)	C1, C2, C3 (S1, S2)	C1, C2, C3 (S1, S2)	C1, C2, C3 (S1, S2)
Heat (if enabled)	2	2	2	2	2	2	2	2	2
Drain	Yes	Yes	Yes	Yes	Yes	Yes	Yes	Yes	Yes
Spin (min.)	0	0	0	0	0	0	0	0	0
Wash 3 (ON/OFF)	OFF	OFF	OFF	OFF	OFF	OFF	OFF	OFF	OFF
Time for agitation (min.)	2	2	2	2	2	2	2	2	2
Fill Temperature	Cold	Cold	Cold	Cold	Cold	Cold	Cold	Cold	Cold
Fill Level	Low	Low	Low	Low	Low	Low	Low	Low	Low
Supply	C1, C2, C3	C1, C2, C3	C1, C2, C3	C1, C2, C3	C1, C2, C3	C1, C2, C3	C1, C2, C3	C1, C2, C3	C1, C2, C3
Heat (if enabled)	2	2	2	2	2	2	2	2	2
Drain	Yes	Yes	Yes	Yes	Yes	Yes	Yes	Yes	Yes
Spin (min.)	0	0	0	0	0	0	0	0	0
Wash 4 (ON/OFF)	OFF	OFF	OFF	OFF	OFF	OFF	OFF	OFF	OFF
Time for agitation (min.)	2	2	2	2	2	2	2	2	2
Fill Temperature	Cold	Cold	Cold	Cold	Cold	Cold	Cold	Cold	Cold
Fill Level	Low	Low	Low	Low	Low	Low	Low	Low	Low
Supply	C1, C2, C3	C1, C2, C3	C1, C2, C3	C1, C2, C3	C1, C2, C3	C1, C2, C3	C1, C2, C3	C1, C2, C3	C1, C2, C3
Heat (if enabled)	2	2	2	2	2	2	2	2	2
Drain	Yes	Yes	Yes	Yes	Yes	Yes	Yes	Yes	Yes
Spin (min.)	0	0	0	0	0	0	0	0	0

(continued)

## Default Cycles

(continued)

Cycle Chart									
Cycle Stops	Normal/ Hot	Normal/ Warm	Normal/ Cold	Heavy/ Hot	Delicate/ Warm	Delicate/ Cold	Quick/ Hot	Quick/ Warm	Quick/ Cold
Cycle reference (display in Program Mode)	CYC1	CYC2	CYC3	CYC4	CYC5	CYC6	CYC7	CYC8	CYC9
Agitation type	18/3/18 Normal	18/3/18 Normal	18/3/18 Normal	18/3/18 Normal	3/12/3 Gentle	3/12/3 Gentle	18/3/18 Normal	18/3/18 Normal	18/3/18 Normal
Rinse 1 (ON/OFF)	ON	ON	ON	ON	ON	ON	ON	ON	ON
Time for agitation (min.)	2	2	2	2	2	2	2	2	2
Fill Temperature	Cold	Cold	Cold	Cold	Cold	Cold	Cold	Cold	Cold
Fill Level	Low	Low	Low	High	High	High	High	High	High
Supply	C1, C2, C3	C1, C2, C3	C1, C2, C3	C1, C2, C3	C1, C2, C3	C1, C2, C3	C1, C2, C3	C1, C2, C3	C1, C2, C3
Heat (if enabled)	0	0	0	0	0	0	0	0	0
Drain	Yes	Yes	Yes	Yes	Yes	Yes	Yes	Yes	Yes
Spin (min.)	0	0	0	0	0	0	0	0	0
Rinse 2 (ON/OFF)	OFF	OFF	OFF	OFF	OFF	OFF	OFF	OFF	OFF
Time for agitation (min.)	2	2	2	2	2	2	2	2	2
Fill Temperature	Cold	Cold	Cold	Cold	Cold	Cold	Cold	Cold	Cold
Fill Level	Low	Low	Low	Low	Low	Low	Low	Low	Low
Supply	C1, C2, C3	C1, C2, C3	C1, C2, C3	C1, C2, C3	C1, C2, C3	C1, C2, C3	C1, C2, C3	C1, C2, C3	C1, C2, C3
Heat (if enabled)	0	0	0	0	0	0	0	0	0
Drain	Yes	Yes	Yes	Yes	Yes	Yes	Yes	Yes	Yes
Spin (min.)	0	0	0	0	0	0	0	0	0
Rinse 3 (ON/OFF)	OFF	OFF	OFF	OFF	OFF	OFF	OFF	OFF	OFF
Time for agitation (min.)	2	2	2	2	3	3	2	2	2
Fill Temperature	Cold	Cold	Cold	Cold	Cold	Cold	Cold	Cold	Cold
Fill Level	High	High	High	High	High	High	Low	Low	Low
Supply	C1, C2, C3	C1, C2, C3	C1, C2, C3	C1, C2, C3	C1, C2, C3	C1, C2, C3	C1, C2, C3	C1, C2, C3	C1, C2, C3
Heat (if enabled)	0	0	0	0	0	0	0	0	0
Drain	Yes	Yes	Yes	Yes	Yes	Yes	Yes	Yes	Yes
Spin (min.)	1 (High)	1 (High)	1 (High)	0	1 (High)	1 (High)	0	0	0
Rinse 4 (ON/OFF)	ON	ON	ON	ON	ON	ON	ON	ON	ON
Time for agitation (min.)	4	4	4	4	2	2	2	2	2
Fill Temperature	Cold	Cold	Cold	Cold	Cold	Cold	Cold	Cold	Cold
Fill Level	Low	Low	Low	Low	Low	Low	Low	Low	Low
Supply	C1, C2, C3, C4 (S3, S4)	C1, C2, C3, C4 (S3, S4)	C1, C2, C3, C4 (S3, S4)	C1, C2, C3 (S3, S4)	C1, C2, C3 (S3, S4)	C1, C2, C3 (S3, S4)	C1, C2, C3 (S3, S4)	C1, C2, C3 (S3, S4)	C1, C2, C3 (S3, S4)
Heat (if enabled)	0	0	0	0	0	0	0	0	0
Drain	Yes	Yes	Yes	Yes	Yes	Yes	Yes	Yes	Yes
Spin (min.)	4 (Very High)	4 (Very High)	4 (Very High)	4 (Very High)	3 (High)	3 (High)	2 (Very High)	2 (Very High)	2 (Very High)
Default Cycle Time	2 speed	00:22:20	00:22:20	00:22:20	00:26:20	00:19:20	00:19:20	00:16:20	00:16:20
(hh:mm:ss)	V or F-speed	00:23:05	00:23:05	00:23:05	00:27:05	00:20:05	00:20:05	00:17:05	00:17:05

Blank Cycle Chart									
Cycle Stops	Normal/ Hot	Normal/ Warm	Normal/ Cold	Heavy/ Hot	Delicate/ Warm	Delicate/ Cold	Quick/ Hot	Quick/ Warm	Quick/ Cold
Cycle reference (display in Program Mode)	CYC1	CYC2	CYC3	CYC4	CYC5	CYC6	CYC7	CYC8	CYC9
Agitation type	18/3/18 Normal	18/3/18 Normal	18/3/18 Normal	18/3/18 Normal	3/12/3 Gentle	3/12/3 Gentle	18/3/18 Normal	18/3/18 Normal	18/3/18 Normal
Wash 1 (ON/OFF)									
Time for agitation (min.)									
Fill Temperature									
Fill Level									
Supply									
Heat (if enabled)									
Drain									
Spin (min.)									
Wash 2 (ON/OFF)									
Time for agitation (min.)									
Fill Temperature									
Fill Level									
Supply									
Heat (if enabled)									
Drain									
Spin (min.)									
Wash 3 (ON/OFF)									
Time for agitation (min.)									
Fill Temperature									
Fill Level									
Supply									
Heat (if enabled)									
Drain									
Spin (min.)									
Wash 4 (ON/OFF)									
Time for agitation (min.)									
Fill Temperature									
Fill Level									
Supply									
Heat (if enabled)									
Drain									
Spin (min.)									

(continued)

## Default Cycles

(continued)

Blank Cycle Chart									
Cycle Stops	Normal/ Hot	Normal/ Warm	Normal/ Cold	Heavy/ Hot	Delicate/ Warm	Delicate/ Cold	Quick/ Hot	Quick/ Warm	Quick/ Cold
Cycle reference (display in Program Mode)	CYC1	CYC2	CYC3	CYC4	CYC5	CYC6	CYC7	CYC8	CYC9
Agitation type	18/3/18 Normal	18/3/18 Normal	18/3/18 Normal	18/3/18 Normal	3/12/3 Gentle	3/12/3 Gentle	18/3/18 Normal	18/3/18 Normal	18/3/18 Normal
Rinse 1 (ON/OFF)									
Time for agitation (min.)									
Fill Temperature									
Fill Level									
Supply									
Heat (if enabled)									
Drain									
Spin (min.)									
Rinse 2 (ON/OFF)									
Time for agitation (min.)									
Fill Temperature									
Fill Level									
Supply									
Heat (if enabled)									
Drain									
Spin (min.)									
Rinse 3 (ON/OFF)									
Time for agitation (min.)									
Fill Temperature									
Fill Level									
Supply									
Heat (if enabled)									
Drain									
Spin (min.)									
Rinse 4 (ON/OFF)									
Time for agitation (min.)									
Fill Temperature									
Fill Level									
Supply									
Heat (if enabled)									
Drain									
Spin (min.)									
Default Cycle Time	2 speed								
(hh:mm:ss)	V or F-speed								

Blank Cycle Chart									
Cycle Stops	Normal/ Hot	Normal/ Warm	Normal/ Cold	Heavy/ Hot	Delicate/ Warm	Delicate/ Cold	Quick/ Hot	Quick/ Warm	Quick/ Cold
Cycle reference (display in Program Mode)	CYC1	CYC2	CYC3	CYC4	CYC5	CYC6	CYC7	CYC8	CYC9
Agitation type	18/3/18 Normal	18/3/18 Normal	18/3/18 Normal	18/3/18 Normal	3/12/3 Gentle	3/12/3 Gentle	18/3/18 Normal	18/3/18 Normal	18/3/18 Normal
Wash 1 (ON/OFF)									
Time for agitation (min.)									
Fill Temperature									
Fill Level									
Supply									
Heat (if enabled)									
Drain									
Spin (min.)									
Wash 2 (ON/OFF)									
Time for agitation (min.)									
Fill Temperature									
Fill Level									
Supply									
Heat (if enabled)									
Drain									
Spin (min.)									
Wash 3 (ON/OFF)									
Time for agitation (min.)									
Fill Temperature									
Fill Level									
Supply									
Heat (if enabled)									
Drain									
Spin (min.)									
Wash 4 (ON/OFF)									
Time for agitation (min.)									
Fill Temperature									
Fill Level									
Supply									
Heat (if enabled)									
Drain									
Spin (min.)									

(continued)

## Default Cycles

(continued)

Blank Cycle Chart									
Cycle Stops	Normal/ Hot	Normal/ Warm	Normal/ Cold	Heavy/ Hot	Delicate/ Warm	Delicate/ Cold	Quick/ Hot	Quick/ Warm	Quick/ Cold
Cycle reference (display in Program Mode)	CYC1	CYC2	CYC3	CYC4	CYC5	CYC6	CYC7	CYC8	CYC9
Agitation type	18/3/18 Normal	18/3/18 Normal	18/3/18 Normal	18/3/18 Normal	3/12/3 Gentle	3/12/3 Gentle	18/3/18 Normal	18/3/18 Normal	18/3/18 Normal
Rinse 1 (ON/OFF)									
Time for agitation (min.)									
Fill Temperature									
Fill Level									
Supply									
Heat (if enabled)									
Drain									
Spin (min.)									
Rinse 2 (ON/OFF)									
Time for agitation (min.)									
Fill Temperature									
Fill Level									
Supply									
Heat (if enabled)									
Drain									
Spin (min.)									
Rinse 3 (ON/OFF)									
Time for agitation (min.)									
Fill Temperature									
Fill Level									
Supply									
Heat (if enabled)									
Drain									
Spin (min.)									
Rinse 4 (ON/OFF)									
Time for agitation (min.)									
Fill Temperature									
Fill Level									
Supply									
Heat (if enabled)									
Drain									
Spin (min.)									
Default Cycle Time	2 speed								
(hh:mm:ss)	V or F-speed								

Blank Cycle Chart									
Cycle Stops	Normal/ Hot	Normal/ Warm	Normal/ Cold	Heavy/ Hot	Delicate/ Warm	Delicate/ Cold	Quick/ Hot	Quick/ Warm	Quick/ Cold
Cycle reference (display in Program Mode)	CYC1	CYC2	CYC3	CYC4	CYC5	CYC6	CYC7	CYC8	CYC9
Agitation type	18/3/18 Normal	18/3/18 Normal	18/3/18 Normal	18/3/18 Normal	3/12/3 Gentle	3/12/3 Gentle	18/3/18 Normal	18/3/18 Normal	18/3/18 Normal
Wash 1 (ON/OFF)									
Time for agitation (min.)									
Fill Temperature									
Fill Level									
Supply									
Heat (if enabled)									
Drain									
Spin (min.)									
Wash 2 (ON/OFF)									
Time for agitation (min.)									
Fill Temperature									
Fill Level									
Supply									
Heat (if enabled)									
Drain									
Spin (min.)									
Wash 3 (ON/OFF)									
Time for agitation (min.)									
Fill Temperature									
Fill Level									
Supply									
Heat (if enabled)									
Drain									
Spin (min.)									
Wash 4 (ON/OFF)									
Time for agitation (min.)									
Fill Temperature									
Fill Level									
Supply									
Heat (if enabled)									
Drain									
Spin (min.)									

(continued)

## Default Cycles

(continued)

Blank Cycle Chart									
Cycle Stops	Normal/ Hot	Normal/ Warm	Normal/ Cold	Heavy/ Hot	Delicate/ Warm	Delicate/ Cold	Quick/ Hot	Quick/ Warm	Quick/ Cold
Cycle reference (display in Program Mode)	CYC1	CYC2	CYC3	CYC4	CYC5	CYC6	CYC7	CYC8	CYC9
Agitation type	18/3/18 Normal	18/3/18 Normal	18/3/18 Normal	18/3/18 Normal	3/12/3 Gentle	3/12/3 Gentle	18/3/18 Normal	18/3/18 Normal	18/3/18 Normal
Rinse 1 (ON/OFF)									
Time for agitation (min.)									
Fill Temperature									
Fill Level									
Supply									
Heat (if enabled)									
Drain									
Spin (min.)									
Rinse 2 (ON/OFF)									
Time for agitation (min.)									
Fill Temperature									
Fill Level									
Supply									
Heat (if enabled)									
Drain									
Spin (min.)									
Rinse 3 (ON/OFF)									
Time for agitation (min.)									
Fill Temperature									
Fill Level									
Supply									
Heat (if enabled)									
Drain									
Spin (min.)									
Rinse 4 (ON/OFF)									
Time for agitation (min.)									
Fill Temperature									
Fill Level									
Supply									
Heat (if enabled)									
Drain									
Spin (min.)									
Default Cycle Time	2 speed								
(hh:mm:ss)	V or F-speed								